

APPENDIX A
Scoping Documents & Correspondence

DDOT - Gorove/Slade Traffic Impact Study Scoping Form

Project Name: 8th and H Streets NE PUD Site Location: South Side of H St., between 8th & 10th Sts.

Purpose of Study: Traffic Impact Assessment Estimated date of Study Completion: 07/13/2007

Brief Description of Project: Mixed Use Development

| Attendee Name: | Representing: | Phone: | EMail: |
|----------------|---------------|--------|--------|
| _____ | _____ | _____ | _____ |
| _____ | _____ | _____ | _____ |
| _____ | _____ | _____ | _____ |
| _____ | _____ | _____ | _____ |
| _____ | _____ | _____ | _____ |
| _____ | _____ | _____ | _____ |
| _____ | _____ | _____ | _____ |
| _____ | _____ | _____ | _____ |
| _____ | _____ | _____ | _____ |

Summary of Draft Trip Generation Impact (Reductions for synergy between uses or transit is NOT applied):

Daily: 2425 IN 2425 OUT AM: 127 IN 111 OUT PM: 191 IN 181 OUT

Attachments:

- DDOT ADT and Classification Maps
- Site location map, including initial traffic distribution thoughts
- Draft Trip Generation Table

| DDOT Guideline | Gorove/Slade Comments & Recommendations | Clarifications/Notes |
|---|--|----------------------|
| <p>1. Scenarios and Planning Horizons</p> <p>“Each traffic impact study shall present an analysis of the traffic conditions without and with the proposed project at two planning year’s horizons: short term and long term... ..The short-term horizon year is defined as one year after occupancy of the project. If the project is proposed to occur over multiple phases, each phase shall be evaluated one year after phase occupancy. The second planning horizon shall be based on the 20-year planning horizon. ”</p> | <p>Due to the limited site trip generation (less than 500 peak hour trips), we propose to evaluate the short-term traffic impacts only, considering a 5-year planning horizon (2013). This is in keeping with ITE recommendations (see attached Table 3-1 at page 13 extracted from “Transportation Impact Analyses for Site Development,” (2005).</p> | |
| <p>2. Peak Hours of Analysis</p> <p>None specified, although AM and PM only is implied.</p> | <p>Since this project concerns residential and community-oriented retail we think that weekday AM and PM peak hours will suffice.</p> | |
| <p>3. Capacity Analyses</p> <p>“... peak hour intersection levels of service shall be determined for signalized and un-signalized intersections within the study area based on procedures described in the latest edition of the Highway Capacity Manual (or equivalent approved by DDOT). The existing arterials shall also be analyzed based on a daily volume/capacity ratio analysis where the threshold capacities are defined by arterial designation per the following table. Volume/capacity ratios that exceed 1.00 shall be identified.”</p> | <p>We will analyze all intersections in the study area using the Synchro 6.0 or Synchro 7.0 software program with HCM methodology (full detailed worksheets will be included in the appendix).</p> <p>A project of this size will have a negligible impact on arterial level of service, and thus roadway v/c ratios will not be calculated.</p> | |
| <p>4. Study Area</p> <p>“At a minimum, the study area shall contain:</p> <ol style="list-style-type: none"> 1. Adjacent and boundary streets and/or natural barriers 1. Nearest arterial/arterial intersection(s) 2. Access roads 3. Internal roads 4. All major signalized or potentially future signalized intersections, either current or future years, where: <ul style="list-style-type: none"> - the project contributes a 10 percent impact (during either the a.m. or p.m. peak hour) to any approach leg of the intersection where the intersection is operating at an acceptable level of service, or - the project contributes a 5 percent impact (during either the a.m. or p.m. peak hour) to any approach leg of the intersection where the intersection is operating at an unacceptable level of service.” | <p>Due to the location of the site along a principal arterial (H Street), its proximity to the DC Downtown, its projected limited site trip generation impacts, and the location of several collector facilities separating the site from other principal arterials to the east and west along H Street, we propose to include all street and alleyway intersections providing immediate access to the block enclosing the site. A figure showing the study intersections is attached.</p> | |

| DDOT Guideline | Gorove/Slade Thoughts | Clarifications/Notes |
|---|---|----------------------|
| <p>5. Site Description</p> <p>“A brief description of the site shall be provided. This should include, as a minimum, a description of its size, general terrain features, existing zoning and use, and proposed zoning and use. A map shall be included showing build-out conditions of the subject property of the following: the street system, roadway classifications, number of travel lanes, street width, existing and proposed ROW dimensions, and, existing and proposed driveways and accesses (with turning movements).”</p> | <p>The study will note the acreage, existing zoning and land uses, as well as the proposed zoning and land uses. A copy of the site plan and other figures will be included to illustrate the build-out conditions.</p> | |
| <p>6. Trip Generation</p> <p>“Trip generation must be calculated from the latest data contained within ITE Trip Generation or other industry publications.... Data limitations, data age, choice of peak hour of adjacent street traffic, choice of independent variable and choice of average rate versus statistical significant modification shall be presented and discussed. In the event that data is not available for a proposed land use, the applicant must conduct a local trip generation study following procedures prescribed in the ITE Trip Generation manual and provide sufficient justification for the proposed generation rate. This rate must be acceptable to DDOT.”</p> | <p>We propose to base residential and retail trip generation on the ITE Trip Generation rates and equations.</p> <p>The independent variable will be the number of units (residential) and per 1000 sq.ft area (retail), based on the final project program.</p> <p>Since ITE rates are based on single use suburban development where virtually all access to the development is by private car, mixed land use synergy and transit usage reductions will be applied to the ITE trip estimates. The WMATA Ridership Survey II will be the basis for transit reductions, and ITE for synergy.</p> | |
| <p>7. Background Forecast – Short Term</p> <p>“The short term traffic forecast shall be the sum of existing traffic volumes plus cumulative development traffic plus ambient growth. The cumulative development traffic shall be based, in part, on the approved project’s a.m. and p.m. peak hour and ADT summary sheets. The short term planning horizon year ambient growth rate traffic forecasts shall be based on:</p> <ul style="list-style-type: none"> - proportion between existing traffic volumes and build-out regional model forecasts - extrapolation from historical traffic counts to current counts, and/or - planning analysis that considers trends in the areas circulation system through either a proportion of extrapolation estimate.” | <p>The Background Traffic Forecast will be based on the following factors:</p> <ol style="list-style-type: none"> a) The projected trip generation and traffic assignment for all planned land use developments likely to impact the study area roadway network, and b) Annual growth in regional/through traffic along H Street by a factor of two percent (2%) per year unto the year following the full occupancy of the proposed development. | |

| DDOT Guideline | Gorove/Slade Thoughts | Clarifications/Notes |
|--|---|----------------------|
| <p>8. Background Forecast – Long Term</p> <p>“Long term a.m. and p.m. peak hour planning horizon traffic forecasts shall be based on the most recent COG traffic forecasts. Requests for forecast shall comply with current COG protocol. It should be noted that the COG forecasts are based on future year population and employment projections that reflect a regional perspective on growth and development. The applicant and consultant shall investigate those land use assumptions as they apply to their project study area and make forecast adjustments as necessary.”</p> | <p>Due to the limited site trip generation (less than 500 peak hour trips), we propose to evaluate the short-term traffic impacts only, considering a 5-year planning horizon (2013). This is in keeping with ITE recommendations (see attached Table 3-1 at page 13 extracted from “Transportation Impact Analyses for Site Development,” (2005).</p> | |
| <p>9. Background Transportation Improvements</p> <p>“The baseline surface transportation network (without the proposed project improvements) assumed for the first planning horizon should reflect existing facilities plus any firmly committed improvements by the District and other developments within the study area. All planned surface transportation facilities within the study area may be included for the baseline assumptions for the long term planning horizon network analysis.”</p> | <p>The study will include all planned and programmed transportation improvements which will impact travel patterns within the immediate study area.</p> | |
| <p>10. Trip Distribution</p> <p>“Trip distribution may be based on COG traffic forecasts, market Analysis, existing traffic flows, applied census data, and professional judgment.”</p> | <p>Our trip distribution assumptions will consider all relevant and available factors, as well as our professional judgment.</p> | |
| <p>11. Project Impacts</p> <p>“The key elements of the project impact analysis include:</p> <ol style="list-style-type: none"> 1. generalized daily traffic volume level of service\ 2. a peak hour intersection level of service <i>The principal objective of the intersection LOS analysis is to identify whether the traffic from the proposed project when added to the existing plus short and long term planning horizon traffic will result in a significant impact and an unacceptable LOS. Significance is defined as: (a) When the added project traffic causes LOS to exceed the established threshold, (b) When the short term or long term horizon year traffic with the project exceeds the established threshold, and the project traffic causes a 2% increase in the v/c ratio or delay.</i> 3. the appropriateness of access locations and the need for future traffic signals 4. turn lane storage requirements 5. sight distance 6. appropriateness of acceleration or deceleration lanes” | <p>As mentioned previously, we do not anticipate performing a roadway v/c ratio, and thus will not be including analysis under category 1.</p> <p>For the intersection LOS analysis, we will assume a threshold of LOS E. We will also list the approach/movement delays where appropriate.</p> <p>We will provide queuing analysis results for all access turn lanes, where appropriate. We do not anticipate the need/desire for a traffic signal.</p> <p>We will perform a sight distance review in the field, but do not plan on incorporating sight triangles onto a CAD drawing to submit with the report, unless specifically requested.</p> | |

| DDOT Guideline | Gorove/Slade Thoughts | Clarifications/Notes |
|--|-----------------------|----------------------|
| <p>12. Special Analysis/Issues</p> <p>“This section provides the District with opportunities to request specific focused traffic analyses germane to the proposed development. These could included access control, access spacing, accident/safety concerns, cut through traffic and residential quality of life, truck estimates and pavement design, accident statistics, pedestrian safety, bicycle safety, safe routes to schools, emergency routes, etc.”</p> | <p>No comments</p> | |

Project Scope agreed to by: _____

Date: _____

DDOT Project Contact: _____

Gorove/Slade Project Contact: [Leon Anderson/ Cullen Elias](#) _____

Date of Request: _____ Date Needed by: [ASAP](#) _____

Request:

DDOT Contact:

Existing Turning Movement Counts within 1 Year

Intersections: _____

Signal Timings for Intersections within Study Area

CAD Drawing of Study Area (ROW, signing, marking, etc.)

ADTs from last ten years in Study Area

Approved Development Details (preferably TIS)

Developments: _____
[Planned developments to be included as background. Copies of the traffic studies preferred.](#) _____

Funded Transportation Improvement Details

Improvements/Studies: _____
[Any roadway improvements that might affect traffic patterns within the study area.](#) _____

Crash/Accident Data within Study Area

Other: _____

APPENDIX B
Levels of Service Description

LEVEL OF SERVICE DEFINITIONS

All capacity analyses are based on the procedures specified by the Transportation Research Board, Special Report 209: *Highway Capacity Manual (HCM)*, 2000. Levels of service (LOS) range from A to F. A brief description of each level of service for signalized and unsignalized intersections is provided below:

{ **Signalized Intersections:** Level of service is based upon the traffic volume present in each lane on the roadway, the capacity of each lane at the intersection and the delay associated with each directional movement. The levels of service for signalized intersections are defined below:

v Level of Service A describes operations with very low average delay per vehicle, i.e., less than 10.0 seconds. This occurs when progression is extremely favorable, and most vehicles arrive during the green phase. Most vehicles do not stop. Short signal cycle lengths may also contribute to low delay.

v Level of Service B describes operations with average delay in the range of 10.1 to 20.0 seconds per vehicle. This generally occurs with good progression and/or short cycle lengths. More vehicles stop than for LOS A, causing higher levels of average delay.

v Level of Service C describes operations with delay in the range of 20.1 to 35.0 seconds per vehicle. These higher delays may result from fair progression and/or longer cycle lengths. Individual cycle failures may begin to appear at this level. The number of vehicles stopping is significant at this level although many still pass through the intersection without stopping. This is generally considered the lower end of the range of the acceptable level of service in rural areas.

v Level of Service D describes operations with delay in the range of 35.1 to 55.0 seconds per vehicle. At LOS D, the influence of congestion becomes more noticeable. Longer delays may result from some combination of unfavorable progression, long cycle lengths, and/or high traffic volumes as compared to the roadway capacity. Many vehicles are required to stop and the number of vehicles that do not have to stop declines. Individual signal cycle failures, where all waiting vehicles do not clear the intersection during a single green time, are noticeable. This is generally considered the lower end of the range of the acceptable level of service in urban areas.

v Level of Service E describes operations with delay in the range of 55.1 to 80.0 seconds per vehicle. These higher delay values generally indicate poor progression, long cycle lengths, and high traffic volumes. Individual cycle failures are frequent occurrences. LOS E has been set as the limit of acceptable conditions.

v Level of Service F describes operations with average delay in excess of 80.0 seconds per vehicle. This is considered to be unacceptable to most drivers. This condition often occurs with over-saturation, i.e., when traffic arrives at a flow rate that exceeds the capacity of the intersection. It may also occur at high volumes with many individual cycle failures. Poor progression and long cycle lengths may also contribute to such delays.

{ **Unsignalized Intersections:** At an unsignalized intersection, the major street through traffic and right turns are assumed to operate unimpeded and therefore receive no level of service rating. The level of service for the minor street and the major street left turn traffic is dependent on the volume and capacity of the available lanes, and, the number and frequency of acceptable gaps in the major street traffic to make a conflicting turn. The level of service grade is provided for each conflicting movement at an unsignalized intersection and is based on the total average delay experienced by each vehicle. The delay includes the time it takes a vehicle to move from the back of a queue through the intersection.

The unsignalized intersection level of service analysis does not account for variations in driver behavior or the effects of nearby traffic signals. Therefore, the results from this analysis usually indicates worse levels of service than may be experienced in the field. The unsignalized intersection level of service descriptions are provided below:

- v Level of Service A. Describes operations where there is very little to no conflicting traffic for a minor side street movement, i.e., an average total delay of less than 10.0 seconds per vehicle.
- v Level of Service B. Describes operations with average total delay in the range of 10.1 to 15.0 seconds per vehicle.
- v Level of Service C. Describes operations with average total delay in the range of 15.1 to 25.0 second per vehicle.
- v Level of Service D. Describes operations with average total delay in the range of 25.1 to 35.0 seconds per vehicle.
- v Level of Service E. Describes operations with average total delay in the range of 35.1 to 50.0 seconds per vehicle.
- v Level of Service F. Describes operations with average total delay of 50 seconds per vehicle. LOS F exists when there are insufficient gaps of suitable size to allow a side street demand to cross safely through or enter a major street traffic stream. This level of service is generally evident from extremely long total delays experienced by side street traffic and by queuing on the minor approaches. It is important to note that LOS F may not always result in long queues but may result in adjustments to normal driver behavior.

APPENDIX C
Existing Traffic Counts

Gorove/Slade Associates

Project Name :
 Project # :
 Location :
 Data Source :

| Intersection: The Alley behind the Plaza on H Street Northeast at 8th Street Northeast | | | | | | | | | | | | | | | | | |
|--|--|--------------------------|------|------|-------------------------------------|--------------------------|------|------|------|--------------------------|------|------|------|-------------------------------------|------|------|------|
| AM PEAK | | Southbound 8th Street | | | | Westbound No Approach | | | | Northbound 8th Street | | | | Eastbound Alley (one-way Wbound) | | | |
| Direction: Roadway: Movement: | | Right | Thru | Left | Peds | Right | Thru | Left | Peds | Right | Thru | Left | Peds | Right | Thru | Left | Peds |
| 6:00 AM to 6:15 AM | | 0 | 12 | 0 | 1 | 1 | 0 | 0 | 0 | 0 | 23 | 0 | 0 | 0 | 0 | 0 | 0 |
| 6:15 AM to 6:30 AM | | 0 | 18 | 0 | 0 | 0 | 0 | 0 | 0 | 0 | 24 | 0 | 0 | 0 | 0 | 0 | 0 |
| 6:30 AM to 6:45 AM | | 0 | 29 | 0 | 0 | 0 | 0 | 0 | 0 | 0 | 33 | 0 | 6 | 0 | 0 | 0 | 0 |
| 6:45 AM to 7:00 AM | | 0 | 35 | 0 | 0 | 0 | 0 | 0 | 0 | 0 | 34 | 0 | 2 | 0 | 0 | 0 | 0 |
| 7:00 AM to 7:15 AM | | 0 | 32 | 1 | 0 | 0 | 0 | 0 | 0 | 0 | 58 | 0 | 10 | 0 | 0 | 0 | 0 |
| 7:15 AM to 7:30 AM | | 0 | 38 | 1 | 0 | 0 | 0 | 0 | 0 | 0 | 59 | 0 | 9 | 0 | 0 | 0 | 0 |
| 7:30 AM to 7:45 AM | | 0 | 36 | 1 | 0 | 0 | 0 | 0 | 0 | 0 | 67 | 0 | 4 | 0 | 0 | 0 | 0 |
| 7:45 AM to 8:00 AM | | 0 | 42 | 0 | 0 | 0 | 0 | 0 | 0 | 0 | 57 | 0 | 2 | 0 | 0 | 0 | 0 |
| 8:00 AM to 8:15 AM | | 0 | 47 | 0 | 0 | 1 | 0 | 0 | 0 | 0 | 57 | 0 | 5 | 0 | 0 | 0 | 0 |
| 8:15 AM to 8:30 AM | | 0 | 57 | 0 | 0 | 0 | 0 | 0 | 0 | 0 | 75 | 0 | 1 | 0 | 0 | 0 | 0 |
| 8:30 AM to 8:45 AM | | 0 | 53 | 0 | 0 | 1 | 0 | 0 | 0 | 0 | 83 | 0 | 7 | 0 | 0 | 0 | 0 |
| 8:45 AM to 9:00 AM | | 0 | 43 | 0 | 0 | 0 | 0 | 0 | 0 | 0 | 69 | 0 | 8 | 0 | 0 | 0 | 0 |
| PM PEAK | | Southbound 8th Street | | | | Westbound No Approach | | | | Northbound 8th Street | | | | Eastbound Alley (one-way Wbound) | | | |
| Direction: Roadway: Movement: | | Right | Thru | Left | Peds | Right | Thru | Left | Peds | Right | Thru | Left | Peds | Right | Thru | Left | Peds |
| 4:00 PM to 4:15 PM | | 0 | 54 | 0 | 0 | 1 | 0 | 0 | 0 | 0 | 76 | 0 | 4 | 0 | 0 | 0 | 0 |
| 4:15 PM to 4:30 PM | | 0 | 57 | 1 | 0 | 1 | 0 | 0 | 0 | 0 | 69 | 0 | 8 | 0 | 0 | 0 | 0 |
| 4:30 PM to 4:45 PM | | 0 | 41 | 1 | 0 | 0 | 0 | 0 | 0 | 0 | 54 | 0 | 11 | 0 | 0 | 0 | 0 |
| 4:45 PM to 5:00 PM | | 0 | 60 | 1 | 0 | 2 | 0 | 0 | 0 | 0 | 73 | 0 | 7 | 0 | 0 | 0 | 0 |
| 5:00 PM to 5:15 PM | | 0 | 61 | 0 | 0 | 0 | 0 | 0 | 0 | 1 | 56 | 0 | 9 | 1 | 0 | 1 | 0 |
| 5:15 PM to 5:30 PM | | 0 | 53 | 0 | 0 | 0 | 0 | 0 | 0 | 0 | 45 | 0 | 8 | 0 | 0 | 0 | 0 |
| 5:30 PM to 5:45 PM | | 1 | 54 | 0 | 0 | 0 | 0 | 0 | 0 | 1 | 52 | 0 | 8 | 1 | 0 | 0 | 0 |
| 5:45 PM to 6:00 PM | | 0 | 59 | 0 | 0 | 0 | 0 | 0 | 0 | 0 | 53 | 0 | 7 | 0 | 0 | 1 | 0 |
| 6:00 PM to 6:15 PM | | 0 | 43 | 0 | 0 | 0 | 1 | 0 | 0 | 0 | 41 | 0 | 8 | 0 | 0 | 0 | 0 |
| 6:15 PM to 6:30 PM | | 0 | 59 | 1 | 0 | 1 | 0 | 0 | 0 | 0 | 50 | 1 | 8 | 0 | 0 | 0 | 0 |
| 6:30 PM to 6:45 PM | | 0 | 35 | 0 | 0 | 0 | 0 | 0 | 0 | 0 | 50 | 0 | 4 | 0 | 0 | 0 | 0 |
| 6:45 PM to 7:00 PM | | 0 | 43 | 0 | 0 | 0 | 0 | 0 | 0 | 0 | 37 | 0 | 8 | 0 | 0 | 0 | 0 |
| PEAK HOURS | | Southbound 8th Street | | | | Westbound No Approach | | | | Northbound 8th Street | | | | Eastbound Alley (one-way Wbound) | | | |
| Direction: Roadway: Movement: | | Right | Thru | Left | Peds | Right | Thru | Left | Peds | Right | Thru | Left | Peds | Right | Thru | Left | Peds |
| AM INTERSECTION PEAK HOUR | | | | | | | | | | | | | | | | | |
| 8:00 AM to 9:00 AM | | 0 | 200 | 0 | 0 | 2 | 0 | 0 | 0 | 0 | 284 | 0 | 21 | 0 | 0 | 0 | 0 |
| PM INTERSECTION PEAK HOUR | | | | | | | | | | | | | | | | | |
| 4:00 PM to 5:00 PM | | 0 | 212 | 3 | 0 | 4 | 0 | 0 | 0 | 0 | 272 | 0 | 30 | 0 | 0 | 0 | 0 |
| AM SYSTEM PEAK HOUR | | | | | | | | | | | | | | | | | |
| 8:00 AM to 9:00 AM | | 0 | 200 | 0 | 0 | 2 | 0 | 0 | 0 | 0 | 284 | 0 | 21 | 0 | 0 | 0 | 0 |
| PM SYSTEM PEAK HOUR | | | | | | | | | | | | | | | | | |
| 4:00 PM to 5:00 PM | | 0 | 212 | 3 | 0 | 4 | 0 | 0 | 0 | 0 | 272 | 0 | 30 | 0 | 0 | 0 | 0 |
| PEAK HOUR FACTORS | | 8th Street | | | | No Approach | | | | 8th Street | | | | Alley (one-way Wbound) | | | |
| AM PEAK HOUR | | 0.00 | 0.88 | 0.00 | N/A | 0.50 | 0.00 | 0.00 | N/A | 0.00 | 0.86 | 0.00 | N/A | 0.00 | 0.00 | 0.00 | N/A |
| PM PEAK HOUR | | 0.00 | 0.88 | 0.75 | N/A | 0.50 | 0.00 | 0.00 | N/A | 0.00 | 0.89 | 0.00 | N/A | 0.00 | 0.00 | 0.00 | N/A |
| Overall AM PEAK HOUR FACTOR = 0.89 | | | | | Overall PM PEAK HOUR FACTOR = 0.90 | | | | | | | | | | | | |
| AM Period Intersection Volume: 1087 | | | | | PM Period Intersection Volume: 1293 | | | | | | | | | | | | |

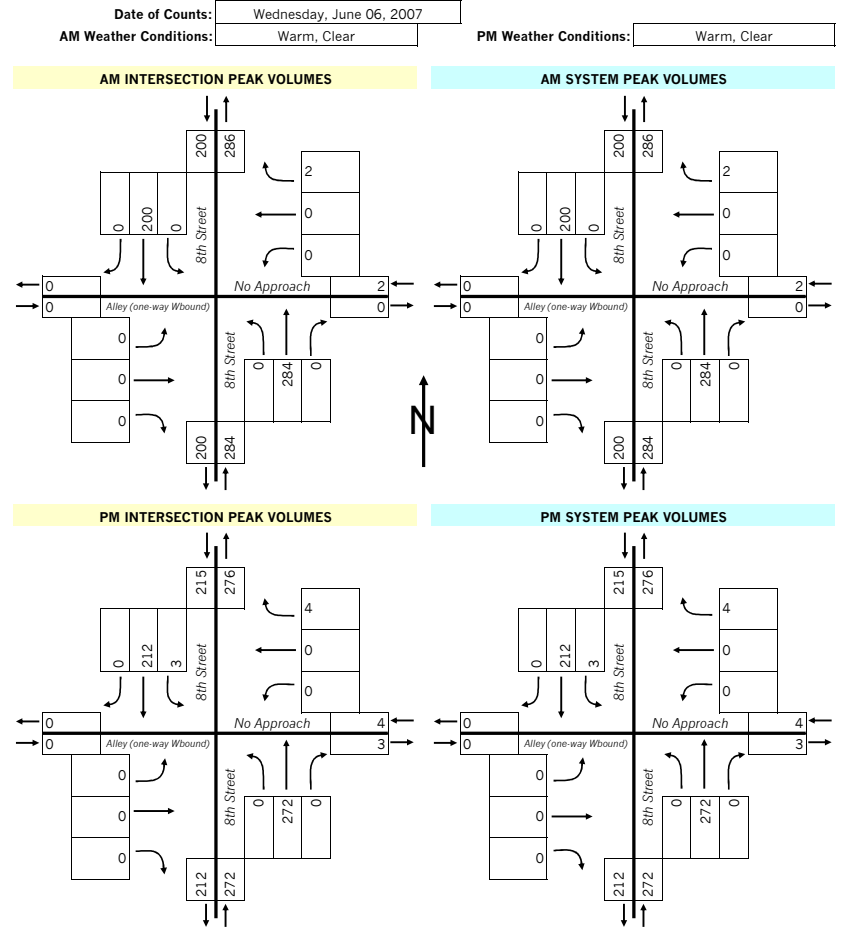

Gorove/Slade Associates

| | |
|----------------|-------------------------|
| Project Name : | 8th Street at H Street |
| Project # : | 2117-001 |
| Location : | DC |
| Data Source : | Gorove/Slade Associates |

| Intersection: | | 8th Street Northeast at H Street Northeast | | | | | | | | | | | | | | | | | | | |
|--|-------------------------------------|--|------|------|------|---------------------------------------|------|------|------|------------------------------------|------|------|------|--------------------|------|------|------|--------|--|--|--|
| AM PEAK | Direction: Roadway: Movement: | Southbound 8th St. | | | | Westbound H St. | | | | Northbound 8th St. | | | | Eastbound H St. | | | | | | | |
| | | Right | Thru | Left | Peds | Right | Thru | Left | Peds | Right | Thru | Left | Peds | Right | Thru | Left | Peds | | | | |
| 6:00 AM to 6:15 AM | | | | | | | | | | 1 | 16 | 4 | 6 | 1 | 20 | 6 | 0 | | | | |
| 6:15 AM to 6:30 AM | | 2 | 10 | 0 | 13 | 19 | 179 | 2 | 3 | 3 | 12 | 3 | 11 | 1 | 28 | 5 | 6 | | | | |
| 6:30 AM to 6:45 AM | | 2 | 16 | 0 | 15 | 2 | 263 | 3 | 10 | 3 | 27 | 1 | 6 | 7 | 36 | 2 | 25 | | | | |
| 6:45 AM to 7:00 AM | | 8 | 25 | 0 | 7 | 5 | 310 | 1 | 10 | 0 | 21 | 2 | 9 | 3 | 33 | 0 | 13 | | | | |
| 7:00 AM to 7:15 AM | | 3 | 25 | 2 | 12 | 1 | 322 | 1 | 15 | 0 | 24 | 4 | 12 | 5 | 58 | 6 | 25 | | | | |
| 7:15 AM to 7:30 AM | | 3 | 39 | 0 | 2 | 4 | 372 | 1 | 21 | 1 | 25 | 5 | 26 | 3 | 73 | 1 | 24 | | | | |
| 7:30 AM to 7:45 AM | | 2 | 28 | 3 | 21 | 2 | 294 | 0 | 14 | 1 | 43 | 3 | 12 | 6 | 64 | 2 | 28 | | | | |
| 7:45 AM to 8:00 AM | | 4 | 45 | 4 | 30 | 5 | 400 | 0 | 18 | 3 | 54 | 2 | 5 | 4 | 83 | 12 | 10 | | | | |
| 8:00 AM to 8:15 AM | | 7 | 38 | 2 | 26 | 5 | 416 | 0 | 23 | 0 | 24 | 2 | 12 | 1 | 99 | 7 | 16 | | | | |
| 8:15 AM to 8:30 AM | | 4 | 44 | 5 | 48 | 6 | 386 | 1 | 33 | 3 | 53 | 1 | 8 | 1 | 78 | 10 | 77 | | | | |
| 8:30 AM to 8:45 AM | | 8 | 52 | 6 | 38 | 7 | 394 | 0 | 21 | 6 | 52 | 1 | 19 | 7 | 83 | 5 | 69 | | | | |
| 8:45 AM to 9:00 AM | | 6 | 45 | 3 | 27 | 4 | 361 | 0 | 30 | 4 | 57 | 4 | 17 | 6 | 79 | 1 | 41 | | | | |
| PM PEAK | Direction: Roadway: Movement: | Southbound 8th St. | | | | Westbound H St. | | | | Northbound 8th St. | | | | Eastbound H St. | | | | | | | |
| 4:00 PM to 4:15 PM | | 8 | 57 | 13 | 43 | 17 | 111 | 2 | 48 | 2 | 73 | 2 | 52 | 5 | 281 | 7 | 111 | | | | |
| 4:15 PM to 4:30 PM | | 14 | 40 | 10 | 59 | 12 | 106 | 3 | 69 | 4 | 54 | 6 | 54 | 13 | 288 | 14 | 93 | | | | |
| 4:30 PM to 4:45 PM | | 14 | 31 | 14 | 83 | 6 | 133 | 1 | 70 | 1 | 50 | 2 | 40 | 9 | 282 | 9 | 103 | | | | |
| 4:45 PM to 5:00 PM | | 8 | 48 | 9 | 56 | 17 | 120 | 0 | 60 | 4 | 66 | 0 | 66 | 2 | 276 | 15 | 77 | | | | |
| 5:00 PM to 5:15 PM | | 13 | 53 | 10 | 34 | 15 | 93 | 1 | 36 | 8 | 46 | 1 | 42 | 22 | 362 | 19 | 20 | | | | |
| 5:15 PM to 5:30 PM | | 8 | 42 | 11 | 45 | 15 | 97 | 0 | 54 | 8 | 18 | 1 | 52 | 4 | 245 | 25 | 46 | | | | |
| 5:30 PM to 5:45 PM | | 4 | 50 | 10 | 68 | 13 | 106 | 10 | 47 | 1 | 28 | 2 | 25 | 3 | 210 | 27 | 21 | | | | |
| 5:45 PM to 6:00 PM | | 10 | 51 | 7 | 44 | 7 | 86 | 1 | 47 | 0 | 46 | 0 | 16 | 21 | 268 | 5 | 35 | | | | |
| 6:00 PM to 6:15 PM | | 6 | 44 | 16 | 48 | 14 | 80 | 3 | 40 | 6 | 43 | 1 | 10 | 6 | 303 | 10 | 20 | | | | |
| 6:15 PM to 6:30 PM | | 9 | 43 | 7 | 38 | 12 | 90 | 2 | 34 | 0 | 26 | 2 | 19 | 1 | 236 | 9 | 32 | | | | |
| 6:30 PM to 6:45 PM | | 11 | 31 | 9 | 43 | 8 | 81 | 2 | 32 | 0 | 40 | 5 | 25 | 0 | 163 | 3 | 28 | | | | |
| 6:45 PM to 7:00 PM | | 8 | 31 | 6 | 36 | 7 | 84 | 7 | 35 | 1 | 20 | 6 | 14 | 4 | 253 | 3 | 48 | | | | |
| PEAK HOURS | Direction: Roadway: Movement: | Southbound 8th St. | | | | Westbound H St. | | | | Northbound 8th St. | | | | Eastbound H St. | | | | | | | |
| AM INTERSECTION PEAK HOUR 7:45 AM to 8:45 AM | | 23 | 179 | 17 | 142 | 23 | 1596 | 1 | 95 | 12 | 183 | 6 | 44 | 13 | 343 | 34 | 172 | | | | |
| PM INTERSECTION PEAK HOUR 4:15 PM to 5:15 PM | | 49 | 172 | 43 | 232 | 50 | 452 | 5 | 235 | 17 | 216 | 9 | 202 | 46 | 1208 | 57 | 293 | | | | |
| AM SYSTEM PEAK HOUR 8:00 AM to 9:00 AM | | 25 | 179 | 16 | 139 | 29 | 1557 | 1 | 107 | 13 | 186 | 8 | 56 | 15 | 339 | 23 | 203 | | | | |
| PM SYSTEM PEAK HOUR 4:00 PM to 5:00 PM | | 44 | 176 | 46 | 241 | 52 | 470 | 6 | 247 | 11 | 243 | 10 | 212 | 29 | 1127 | 45 | 384 | | | | |
| PEAK HOUR FACTORS | | Southbound 8th St. | | | | Westbound H St. | | | | Northbound 8th St. | | | | Eastbound H St. | | | | | | | |
| AM PEAK HOUR | | 0.78 | 0.86 | 0.67 | N/A | 1.04 | 0.94 | 0.25 | N/A | 0.54 | 0.82 | 0.50 | N/A | 0.54 | 0.86 | 0.58 | N/A | | | | |
| PM PEAK HOUR | | 0.79 | 0.77 | 0.82 | N/A | 0.76 | 0.88 | 0.50 | N/A | 0.69 | 0.83 | 0.42 | N/A | 0.56 | 0.98 | 0.75 | N/A | | | | |
| Overall AM PEAK HOUR FACTOR | | = 0.96 | | | | | | | | Overall PM PEAK HOUR FACTOR | | | | | | | | = 0.98 | | | |
| AM Period Intersection Volume: | | 5508 | | | | PM Period Intersection Volume: | | | | 6094 | | | | | | | | | | | |

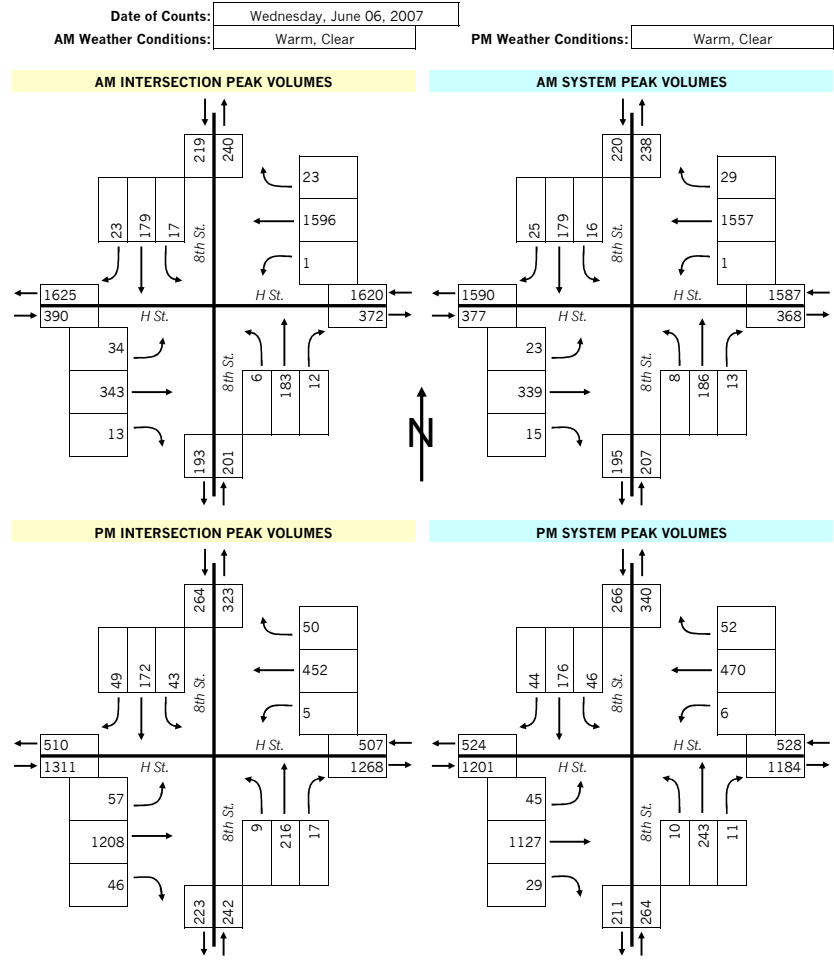

Gorove/Slade Associates

| | |
|-----------------|-------------------------|
| Project Name : | 8th Street at H Street |
| Project Number: | 2117-001 |
| Location: | DC |
| Data Source: | Gorove/Slade Associates |

| Intersection: | | 8th Street Northeast at G Street Northeast | | | | | | | | | | | | | | | |
|--|-------------------------------------|--|------|------|------|---------------------------------------|------|------|------|------------------------------------|------|------|------|----------------------|------|------|------|
| AM PEAK | Direction: Roadway: Movement: | Southbound 8th St. | | | | Westbound G St. | | | | Northbound 8th St. | | | | Eastbound One-Way | | | |
| | | Right | Thru | Left | Peds | Right | Thru | Left | Peds | Right | Thru | Left | Peds | Right | Thru | Left | Peds |
| 6:00 AM to 6:15 AM | | 2 | 10 | 0 | 1 | 2 | 12 | 1 | 3 | 0 | 24 | 0 | 2 | 0 | 0 | 0 | 1 |
| 6:15 AM to 6:30 AM | | 0 | 17 | 0 | 2 | 5 | 7 | 1 | 1 | 0 | 18 | 0 | 3 | 0 | 0 | 0 | 0 |
| 6:30 AM to 6:45 AM | | 1 | 29 | 0 | 2 | 7 | 16 | 1 | 1 | 0 | 29 | 1 | 9 | 0 | 0 | 0 | 2 |
| 6:45 AM to 7:00 AM | | 0 | 32 | 0 | 1 | 6 | 8 | 0 | 1 | 0 | 24 | 5 | 3 | 0 | 0 | 0 | 4 |
| 7:00 AM to 7:15 AM | | 3 | 27 | 0 | 1 | 7 | 20 | 2 | 3 | 0 | 53 | 9 | 4 | 0 | 0 | 0 | 3 |
| 7:15 AM to 7:30 AM | | 0 | 44 | 0 | 1 | 9 | 34 | 5 | 6 | 0 | 50 | 6 | 3 | 0 | 0 | 0 | 1 |
| 7:30 AM to 7:45 AM | | 2 | 33 | 0 | 0 | 12 | 31 | 6 | 7 | 8 | 50 | 7 | 2 | 0 | 0 | 0 | 0 |
| 7:45 AM to 8:00 AM | | 1 | 43 | 0 | 2 | 8 | 53 | 3 | 15 | 0 | 46 | 3 | 7 | 0 | 0 | 0 | 3 |
| 8:00 AM to 8:15 AM | | 5 | 36 | 0 | 3 | 10 | 72 | 7 | 6 | 0 | 47 | 13 | 4 | 0 | 0 | 0 | 4 |
| 8:15 AM to 8:30 AM | | 3 | 52 | 0 | 4 | 16 | 73 | 3 | 6 | 0 | 64 | 15 | 1 | 0 | 0 | 0 | 3 |
| 8:30 AM to 8:45 AM | | 7 | 47 | 0 | 12 | 15 | 70 | 0 | 13 | 0 | 66 | 9 | 2 | 0 | 0 | 0 | 2 |
| 8:45 AM to 9:00 AM | | 4 | 45 | 0 | 2 | 16 | 62 | 1 | 9 | 0 | 67 | 10 | 4 | 0 | 0 | 0 | 1 |
| PM PEAK | Direction: Roadway: Movement: | Southbound 8th St. | | | | Westbound G St. | | | | Northbound 8th St. | | | | Eastbound One-Way | | | |
| | | Right | Thru | Left | Peds | Right | Thru | Left | Peds | Right | Thru | Left | Peds | Right | Thru | Left | Peds |
| 4:00 PM to 4:15 PM | | 1 | 52 | 0 | 5 | 17 | 29 | 0 | 6 | 0 | 55 | 9 | 1 | 0 | 0 | 0 | 2 |
| 4:15 PM to 4:30 PM | | 2 | 50 | 0 | 5 | 11 | 20 | 3 | 3 | 0 | 59 | 8 | 0 | 0 | 0 | 0 | 0 |
| 4:30 PM to 4:45 PM | | 0 | 39 | 0 | 0 | 11 | 19 | 1 | 2 | 0 | 51 | 3 | 5 | 0 | 0 | 0 | 0 |
| 4:45 PM to 5:00 PM | | 5 | 54 | 0 | 4 | 9 | 18 | 3 | 7 | 0 | 58 | 7 | 3 | 0 | 1 | 0 | 5 |
| 5:00 PM to 5:15 PM | | 4 | 62 | 0 | 2 | 10 | 19 | 5 | 5 | 0 | 43 | 9 | 5 | 0 | 1 | 0 | 1 |
| 5:15 PM to 5:30 PM | | 2 | 50 | 0 | 1 | 8 | 16 | 2 | 7 | 0 | 40 | 7 | 5 | 0 | 0 | 0 | 4 |
| 5:30 PM to 5:45 PM | | 4 | 54 | 0 | 6 | 6 | 17 | 2 | 6 | 0 | 47 | 6 | 7 | 0 | 0 | 0 | 2 |
| 5:45 PM to 6:00 PM | | 2 | 59 | 0 | 5 | 7 | 15 | 4 | 3 | 0 | 49 | 5 | 3 | 0 | 0 | 0 | 6 |
| 6:00 PM to 6:15 PM | | 1 | 50 | 0 | 3 | 6 | 11 | 2 | 7 | 0 | 47 | 9 | 5 | 0 | 0 | 0 | 4 |
| 6:15 PM to 6:30 PM | | 1 | 53 | 0 | 7 | 12 | 10 | 4 | 2 | 0 | 43 | 5 | 8 | 0 | 0 | 0 | 5 |
| 6:30 PM to 6:45 PM | | 3 | 41 | 0 | 5 | 10 | 11 | 3 | 6 | 0 | 46 | 2 | 9 | 0 | 0 | 0 | 7 |
| 6:45 PM to 7:00 PM | | 3 | 40 | 2 | 6 | 6 | 18 | 0 | 2 | 0 | 35 | 9 | 9 | 0 | 0 | 0 | 0 |
| PEAK HOURS | Direction: Roadway: Movement: | Southbound 8th St. | | | | Westbound G St. | | | | Northbound 8th St. | | | | Eastbound One-Way | | | |
| | | Right | Thru | Left | Peds | Right | Thru | Left | Peds | Right | Thru | Left | Peds | Right | Thru | Left | Peds |
| AM INTERSECTION PEAK HOUR 8:00 AM to 9:00 AM | | 19 | 180 | 0 | 21 | 57 | 277 | 11 | 34 | 0 | 244 | 47 | 11 | 0 | 0 | 0 | 10 |
| PM INTERSECTION PEAK HOUR 4:00 PM to 5:00 PM | | 8 | 195 | 0 | 14 | 48 | 86 | 7 | 18 | 0 | 223 | 27 | 9 | 0 | 1 | 0 | 7 |
| AM SYSTEM PEAK HOUR 8:00 AM to 9:00 AM | | 19 | 180 | 0 | 21 | 57 | 277 | 11 | 34 | 0 | 244 | 47 | 11 | 0 | 0 | 0 | 10 |
| PM SYSTEM PEAK HOUR 4:00 PM to 5:00 PM | | 8 | 195 | 0 | 14 | 48 | 86 | 7 | 18 | 0 | 223 | 27 | 9 | 0 | 1 | 0 | 7 |
| PEAK HOUR | FACTORS | 8th St. | | | | G St. | | | | 8th St. | | | | One-Way | | | |
| | | Right | Thru | Left | Peds | Right | Thru | Left | Peds | Right | Thru | Left | Peds | Right | Thru | Left | Peds |
| | AM PEAK HOUR | 0.68 | 0.87 | 0.00 | N/A | 0.89 | 0.95 | 0.39 | N/A | 0.00 | 0.91 | 0.78 | N/A | 0.00 | 0.00 | 0.00 | N/A |
| | PM PEAK HOUR | 0.40 | 0.90 | 0.00 | N/A | 0.71 | 0.74 | 0.58 | N/A | 0.00 | 0.94 | 0.75 | N/A | 0.00 | 0.25 | 0.00 | N/A |
| | Overall AM PEAK HOUR FACTOR | = 0.92 | | | | | | | | Overall PM PEAK HOUR FACTOR | | | | | | | |
| | Overall PM PEAK HOUR FACTOR | = 0.91 | | | | | | | | | | | | | | | |
| AM Period Intersection Volume: | | 1668 | | | | PM Period Intersection Volume: | | | | 1633 | | | | | | | |

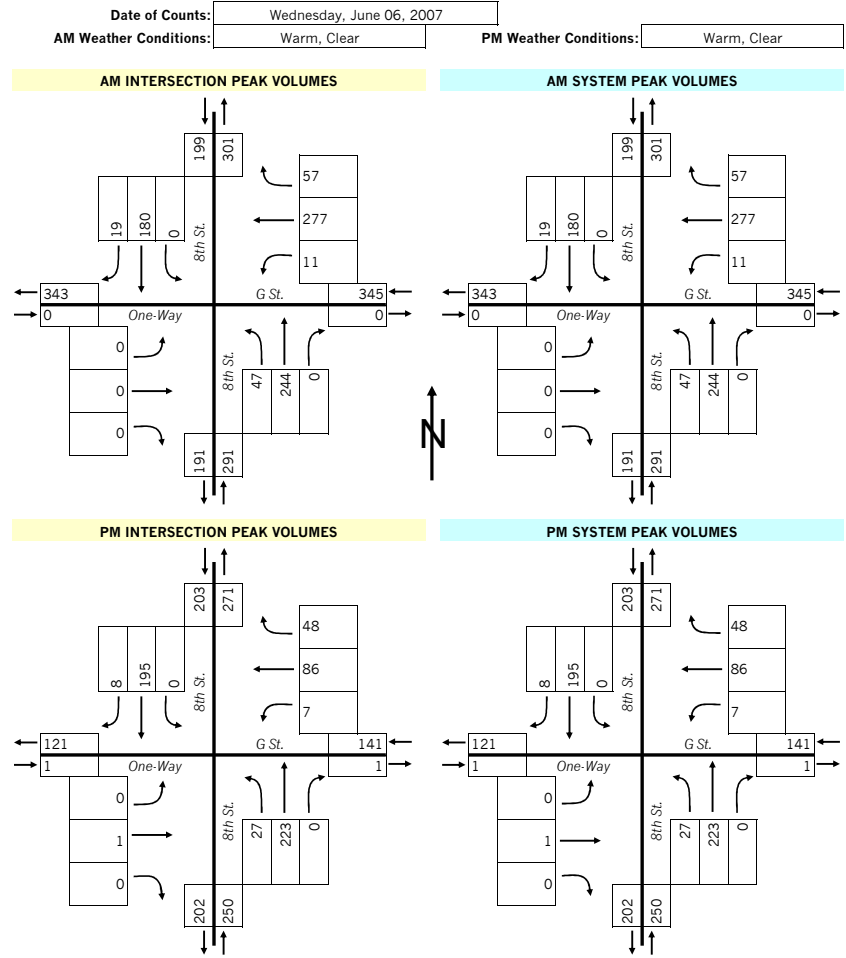

Gorove/Slade Associates

| | |
|-----------------|-------------------------|
| Project Name : | 8th Street at H Street |
| Project Number: | 2117-001 |
| Location: | DC |
| Data Source: | Gorove/Slade Associates |

| Intersection: | | 10th Street Northeast at G Street Northeast | | | | | | | | | | | | | | | |
|---------------------------------------|-------------------------------------|---|------|------|------|--------------------|------|------|------|---------------------------------------|------|------|------|----------------------|------|------|------|
| AM PEAK | Direction: Roadway: Movement: | Southbound 10th St. | | | | Westbound G St. | | | | Northbound 10th St. | | | | Eastbound One-Way | | | |
| | | Right | Thru | Left | Peds | Right | Thru | Left | Peds | Right | Thru | Left | Peds | Right | Thru | Left | Peds |
| | | 6:00 AM to 6:15 AM | 3 | 4 | 0 | 3 | 2 | 10 | 0 | 0 | 0 | 1 | 1 | 2 | 0 | 1 | 0 |
| 6:15 AM to 6:30 AM | 1 | 2 | 0 | 2 | 2 | 8 | 0 | 2 | 0 | 2 | 1 | 0 | 0 | 0 | 0 | 0 | |
| 6:30 AM to 6:45 AM | 3 | 3 | 0 | 0 | 1 | 16 | 0 | 2 | 0 | 4 | 1 | 5 | 0 | 0 | 0 | 3 | |
| 6:45 AM to 7:00 AM | 3 | 11 | 0 | 4 | 1 | 6 | 0 | 3 | 0 | 6 | 3 | 4 | 0 | 0 | 0 | 3 | |
| 7:00 AM to 7:15 AM | 6 | 8 | 0 | 1 | 1 | 20 | 1 | 0 | 0 | 5 | 1 | 3 | 0 | 0 | 0 | 1 | |
| 7:15 AM to 7:30 AM | 1 | 9 | 0 | 7 | 3 | 29 | 4 | 8 | 0 | 2 | 11 | 0 | 0 | 0 | 0 | 1 | |
| 7:30 AM to 7:45 AM | 7 | 7 | 0 | 3 | 7 | 32 | 1 | 4 | 0 | 10 | 4 | 6 | 0 | 0 | 0 | 3 | |
| 7:45 AM to 8:00 AM | 2 | 18 | 0 | 6 | 9 | 63 | 1 | 8 | 0 | 4 | 3 | 8 | 0 | 0 | 0 | 1 | |
| 8:00 AM to 8:15 AM | 8 | 11 | 0 | 8 | 2 | 56 | 2 | 10 | 0 | 10 | 6 | 5 | 0 | 0 | 0 | 6 | |
| 8:15 AM to 8:30 AM | 8 | 23 | 0 | 5 | 5 | 64 | 1 | 9 | 0 | 22 | 10 | 3 | 0 | 0 | 0 | 8 | |
| 8:30 AM to 8:45 AM | 5 | 23 | 0 | 11 | 7 | 59 | 1 | 10 | 0 | 10 | 7 | 6 | 0 | 0 | 0 | 2 | |
| 8:45 AM to 9:00 AM | 3 | 16 | 0 | 4 | 5 | 56 | 1 | 1 | 0 | 13 | 10 | 5 | 0 | 0 | 0 | 5 | |
| PM PEAK | Direction: Roadway: Movement: | Southbound 10th St. | | | | Westbound G St. | | | | Northbound 10th St. | | | | Eastbound One-Way | | | |
| | | Right | Thru | Left | Peds | Right | Thru | Left | Peds | Right | Thru | Left | Peds | Right | Thru | Left | Peds |
| | | 4:00 PM to 4:15 PM | 5 | 24 | 0 | 9 | 6 | 24 | 0 | 2 | 0 | 26 | 6 | 3 | 0 | 0 | 0 |
| 4:15 PM to 4:30 PM | 5 | 21 | 0 | 1 | 4 | 23 | 0 | 10 | 0 | 23 | 4 | 6 | 0 | 0 | 0 | 4 | |
| 4:30 PM to 4:45 PM | 3 | 23 | 0 | 4 | 5 | 14 | 2 | 9 | 0 | 15 | 4 | 7 | 0 | 0 | 0 | 3 | |
| 4:45 PM to 5:00 PM | 5 | 26 | 0 | 4 | 3 | 14 | 4 | 7 | 0 | 20 | 3 | 10 | 0 | 0 | 0 | 7 | |
| 5:00 PM to 5:15 PM | 3 | 23 | 0 | 6 | 5 | 14 | 2 | 12 | 0 | 11 | 7 | 1 | 0 | 0 | 0 | 8 | |
| 5:15 PM to 5:30 PM | 6 | 27 | 0 | 6 | 4 | 13 | 1 | 3 | 1 | 13 | 8 | 5 | 0 | 0 | 0 | 4 | |
| 5:30 PM to 5:45 PM | 3 | 23 | 0 | 13 | 4 | 14 | 1 | 3 | 0 | 11 | 5 | 2 | 0 | 0 | 0 | 4 | |
| 5:45 PM to 6:00 PM | 5 | 20 | 0 | 10 | 8 | 14 | 0 | 3 | 0 | 14 | 3 | 5 | 0 | 0 | 0 | 8 | |
| 6:00 PM to 6:15 PM | 3 | 24 | 0 | 3 | 5 | 11 | 3 | 10 | 0 | 22 | 5 | 6 | 0 | 0 | 0 | 12 | |
| 6:15 PM to 6:30 PM | 1 | 21 | 0 | 6 | 3 | 16 | 4 | 3 | 0 | 5 | 6 | 8 | 0 | 0 | 0 | 8 | |
| 6:30 PM to 6:45 PM | 7 | 18 | 0 | 3 | 5 | 9 | 2 | 6 | 0 | 13 | 2 | 4 | 0 | 0 | 0 | 20 | |
| 6:45 PM to 7:00 PM | 4 | 17 | 0 | 3 | 4 | 15 | 1 | 10 | 0 | 12 | 5 | 8 | 0 | 0 | 0 | 6 | |
| PEAK HOURS | Direction: Roadway: Movement: | Southbound 10th St. | | | | Westbound G St. | | | | Northbound 10th St. | | | | Eastbound One-Way | | | |
| AM INTERSECTION PEAK HOUR | | Right | Thru | Left | Peds | Right | Thru | Left | Peds | Right | Thru | Left | Peds | Right | Thru | Left | Peds |
| 8:00 AM to 9:00 AM | | 24 | 73 | 0 | 28 | 19 | 235 | 5 | 30 | 0 | 55 | 33 | 19 | 0 | 0 | 0 | 21 |
| PM INTERSECTION PEAK HOUR | | Right | Thru | Left | Peds | Right | Thru | Left | Peds | Right | Thru | Left | Peds | Right | Thru | Left | Peds |
| 4:00 PM to 5:00 PM | | 18 | 94 | 0 | 18 | 18 | 75 | 6 | 28 | 0 | 84 | 17 | 26 | 0 | 0 | 0 | 24 |
| AM SYSTEM PEAK HOUR | | Right | Thru | Left | Peds | Right | Thru | Left | Peds | Right | Thru | Left | Peds | Right | Thru | Left | Peds |
| 8:00 AM to 9:00 AM | | 24 | 73 | 0 | 28 | 19 | 235 | 5 | 30 | 0 | 55 | 33 | 19 | 0 | 0 | 0 | 21 |
| PM SYSTEM PEAK HOUR | | Right | Thru | Left | Peds | Right | Thru | Left | Peds | Right | Thru | Left | Peds | Right | Thru | Left | Peds |
| 4:00 PM to 5:00 PM | | 18 | 94 | 0 | 18 | 18 | 75 | 6 | 28 | 0 | 84 | 17 | 26 | 0 | 0 | 0 | 24 |
| PEAK HOUR | Direction: Roadway: Movement: | Southbound 10th St. | | | | Westbound G St. | | | | Northbound 10th St. | | | | Eastbound One-Way | | | |
| FACTORS | | Right | Thru | Left | Peds | Right | Thru | Left | Peds | Right | Thru | Left | Peds | Right | Thru | Left | Peds |
| AM PEAK HOUR | | 0.75 | 0.79 | 0.00 | N/A | 0.68 | 0.92 | 0.63 | N/A | 0.00 | 0.63 | 0.83 | N/A | 0.00 | 0.00 | 0.00 | N/A |
| PM PEAK HOUR | | 0.90 | 0.90 | 0.00 | N/A | 0.75 | 0.78 | 0.38 | N/A | 0.00 | 0.81 | 0.71 | N/A | 0.00 | 0.00 | 0.00 | N/A |
| Overall AM PEAK HOUR FACTOR | | = 0.83 | | | | | | | | Overall PM PEAK HOUR FACTOR | | | | | | | |
| AM Period Intersection Volume: | | 809 | | | | | | | | PM Period Intersection Volume: | | | | | | | |
| | | 818 | | | | | | | | | | | | | | | |

Date of Counts: Wednesday, June 06, 2007
 AM Weather Conditions: Warm, Clear
 PM Weather Conditions: Warm, Clear

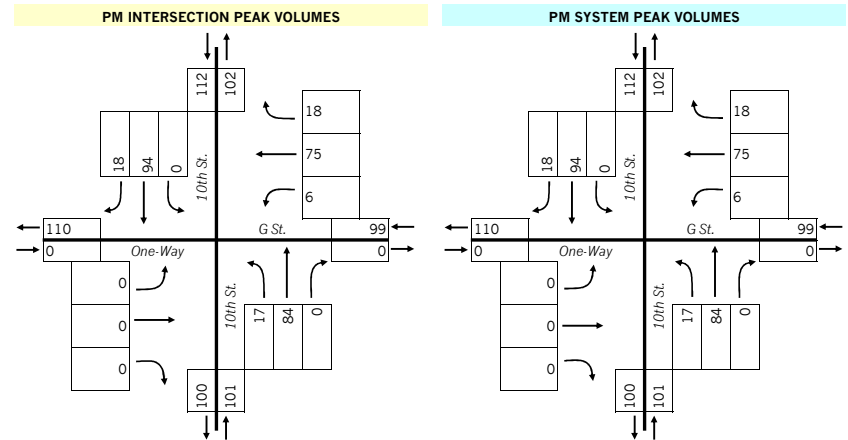
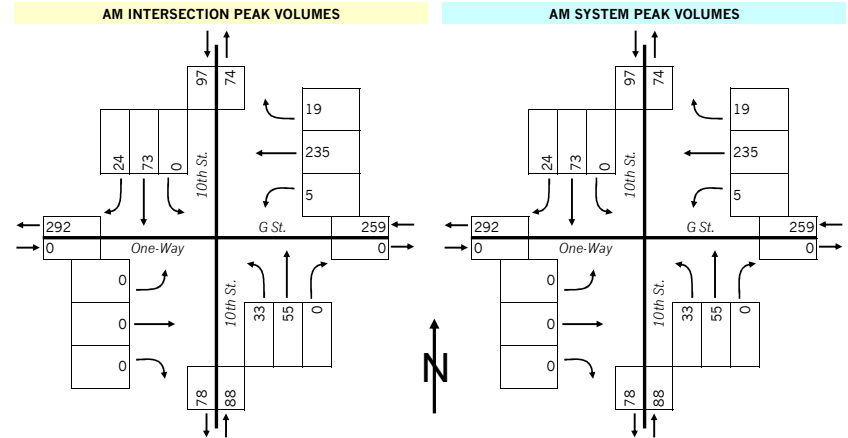

Gorove/Slade Associates

Project Name : 8th Street at H Street
 Project Number: 2117-001
 Location: DC
 Data Source: Gorove/Slade Associates

| Intersection: | | 9th Street Northeast at H Street Northeast | | | | | | | | | | | | | | | |
|--------------------------------|-------------------------------------|--|------|------|------|--------------------|------|------|------|-----------------------|------|------|------|--------------------|------|------|------|
| AM PEAK | Direction: Roadway: Movement: | Southbound 9th St. | | | | Westbound H St. | | | | Northbound 9th St. | | | | Eastbound H St. | | | |
| | | Right | Thru | Left | Peds | Right | Thru | Left | Peds | Right | Thru | Left | Peds | Right | Thru | Left | Peds |
| 6:00 AM to 6:15 AM | | 2 | 0 | 0 | 3 | 1 | 0 | 1 | 1 | 0 | 0 | 0 | 1 | 0 | 0 | 0 | 0 |
| 6:15 AM to 6:30 AM | | 5 | 2 | 0 | 2 | 3 | 0 | 1 | 4 | 1 | 0 | 1 | 1 | 1 | 0 | 0 | 3 |
| 6:30 AM to 6:45 AM | | 5 | 0 | 2 | 3 | 2 | 0 | 1 | 2 | 0 | 1 | 1 | 2 | 1 | 0 | 2 | 5 |
| 6:45 AM to 7:00 AM | | 3 | 0 | 3 | 1 | 5 | 0 | 0 | 3 | 0 | 0 | 0 | 5 | 3 | 0 | 0 | 5 |
| 7:00 AM to 7:15 AM | | 4 | 1 | 0 | 3 | 2 | 0 | 1 | 2 | 0 | 1 | 1 | 2 | 0 | 0 | 3 | 8 |
| 7:15 AM to 7:30 AM | | 6 | 1 | 2 | 7 | 5 | 0 | 0 | 5 | 1 | 1 | 0 | 3 | 1 | 0 | 2 | 3 |
| 7:30 AM to 7:45 AM | | 5 | 0 | 1 | 6 | 12 | 0 | 2 | 3 | 3 | 0 | 1 | 5 | 3 | 0 | 1 | 13 |
| 7:45 AM to 8:00 AM | | 6 | 1 | 3 | 5 | 18 | 0 | 1 | 5 | 0 | 1 | 3 | 7 | 0 | 0 | 0 | 4 |
| 8:00 AM to 8:15 AM | | 3 | 1 | 3 | 3 | 19 | 0 | 0 | 10 | 1 | 0 | 1 | 9 | 4 | 0 | 1 | 8 |
| 8:15 AM to 8:30 AM | | 2 | 2 | 4 | 6 | 21 | 0 | 3 | 13 | 2 | 2 | 3 | 4 | 2 | 0 | 1 | 6 |
| 8:30 AM to 8:45 AM | | 2 | 0 | 4 | 10 | 15 | 0 | 2 | 5 | 1 | 2 | 2 | 12 | 3 | 0 | 1 | 20 |
| 8:45 AM to 9:00 AM | | 2 | 3 | 2 | 9 | 25 | 0 | 0 | 9 | 3 | 3 | 4 | 12 | 3 | 1 | 4 | 8 |
| PM PEAK | Direction: Roadway: Movement: | Southbound 9th St. | | | | Westbound H St. | | | | Northbound 9th St. | | | | Eastbound H St. | | | |
| | | Right | Thru | Left | Peds | Right | Thru | Left | Peds | Right | Thru | Left | Peds | Right | Thru | Left | Peds |
| 4:00 PM to 4:15 PM | | 3 | 3 | 7 | 22 | 8 | 0 | 3 | 12 | 2 | 4 | 4 | 7 | 5 | 0 | 4 | 21 |
| 4:15 PM to 4:30 PM | | 8 | 5 | 9 | 18 | 19 | 0 | 2 | 22 | 8 | 6 | 1 | 19 | 4 | 0 | 1 | 39 |
| 4:30 PM to 4:45 PM | | 4 | 3 | 8 | 30 | 10 | 0 | 6 | 24 | 11 | 2 | 9 | 20 | 9 | 0 | 7 | 41 |
| 4:45 PM to 5:00 PM | | 3 | 4 | 8 | 31 | 14 | 0 | 4 | 24 | 8 | 2 | 6 | 7 | 6 | 0 | 3 | 27 |
| 5:00 PM to 5:15 PM | | 5 | 4 | 10 | 31 | 12 | 0 | 0 | 22 | 4 | 3 | 4 | 17 | 11 | 0 | 4 | 14 |
| 5:15 PM to 5:30 PM | | 4 | 2 | 8 | 28 | 6 | 0 | 3 | 16 | 10 | 2 | 2 | 19 | 6 | 0 | 8 | 22 |
| 5:30 PM to 5:45 PM | | 4 | 3 | 7 | 15 | 13 | 0 | 4 | 11 | 5 | 5 | 8 | 7 | 8 | 0 | 4 | 28 |
| 5:45 PM to 6:00 PM | | 2 | 2 | 6 | 21 | 9 | 0 | 4 | 8 | 7 | 2 | 3 | 17 | 9 | 0 | 6 | 34 |
| 6:00 PM to 6:15 PM | | 6 | 3 | 7 | 21 | 11 | 0 | 4 | 17 | 9 | 3 | 8 | 6 | 13 | 0 | 3 | 19 |
| 6:15 PM to 6:30 PM | | 6 | 3 | 6 | 14 | 8 | 0 | 2 | 10 | 5 | 5 | 6 | 6 | 5 | 0 | 2 | 28 |
| 6:30 PM to 6:45 PM | | 4 | 1 | 8 | 20 | 10 | 0 | 4 | 8 | 7 | 7 | 5 | 5 | 6 | 0 | 1 | 7 |
| 6:45 PM to 7:00 PM | | 1 | 0 | 5 | 14 | 8 | 0 | 4 | 12 | 4 | 2 | 5 | 6 | 10 | 0 | 2 | 10 |
| PEAK HOURS | Direction: Roadway: Movement: | Southbound 9th St. | | | | Westbound H St. | | | | Northbound 9th St. | | | | Eastbound H St. | | | |
| AM INTERSECTION PEAK HOUR | 8:00 AM to 9:00 AM | 9 | 6 | 13 | 28 | 80 | 0 | 5 | 37 | 7 | 7 | 10 | 37 | 12 | 1 | 7 | 42 |
| PM INTERSECTION PEAK HOUR | 4:15 PM to 5:15 PM | 20 | 16 | 35 | 110 | 55 | 0 | 12 | 92 | 31 | 13 | 20 | 63 | 30 | 0 | 15 | 121 |
| AM SYSTEM PEAK HOUR | 8:00 AM to 9:00 AM | 9 | 6 | 13 | 28 | 80 | 0 | 5 | 37 | 7 | 7 | 10 | 37 | 12 | 1 | 7 | 42 |
| PM SYSTEM PEAK HOUR | 4:00 PM to 5:00 PM | 18 | 15 | 32 | 101 | 51 | 0 | 15 | 82 | 29 | 14 | 20 | 53 | 24 | 0 | 15 | 128 |
| PEAK HOUR FACTORS | | 9th St. | | | | H St. | | | | 9th St. | | | | H St. | | | |
| AM PEAK HOUR | | 0.75 | 0.50 | 0.81 | N/A | 0.80 | 0.00 | 0.42 | N/A | 0.58 | 0.58 | 0.63 | N/A | 0.75 | 0.25 | 0.44 | N/A |
| PM PEAK HOUR | | 0.56 | 0.75 | 0.89 | N/A | 0.67 | 0.00 | 0.63 | N/A | 0.66 | 0.58 | 0.56 | N/A | 0.67 | 0.00 | 0.54 | N/A |
| Overall AM PEAK HOUR FACTOR | | = 0.79 | | | | | | | | | | | | | | | |
| Overall PM PEAK HOUR FACTOR | | = 0.84 | | | | | | | | | | | | | | | |
| AM Period Intersection Volume: | | 297 | | | | | | | | | | | | | | | |
| PM Period Intersection Volume: | | 661 | | | | | | | | | | | | | | | |

Date of Counts: Wednesday, June 06, 2007
 AM Weather Conditions: Warm, Clear
 PM Weather Conditions: Warm, Clear

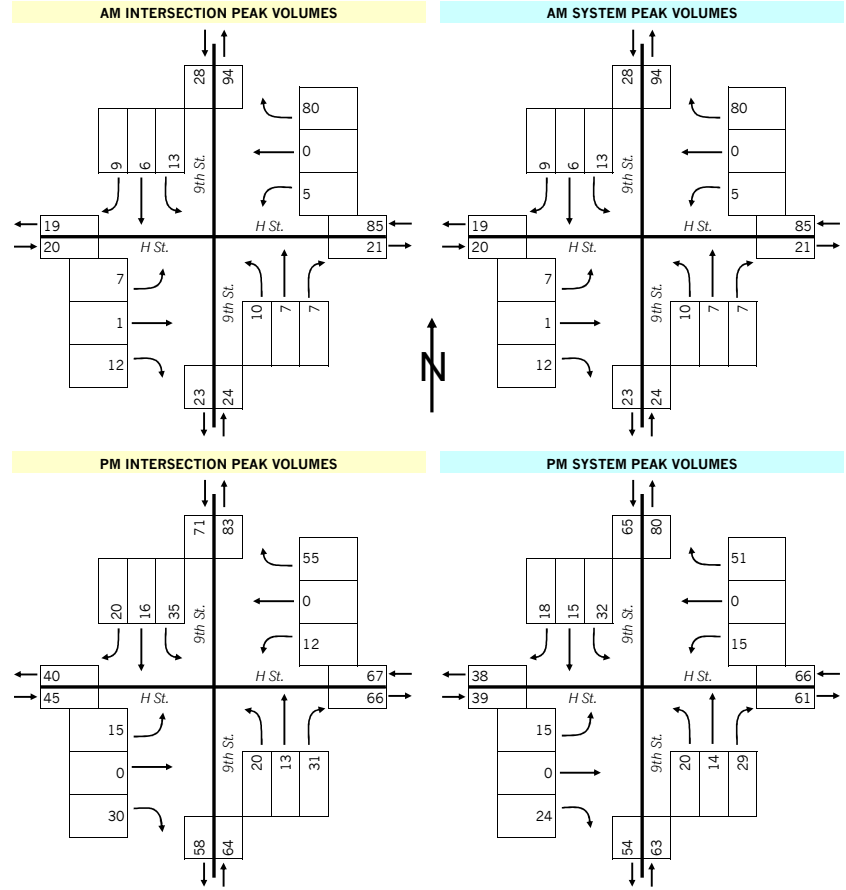

Gorove/Slade Associates

| | |
|-----------------|-------------------------|
| Project Name : | 8th Street at H Street |
| Project Number: | 2117-001 |
| Location: | DC |
| Data Source: | Gorove/Slade Associates |

| Intersection: | | 10th Street Northeast at H Street Northeast | | | | | | | | | | | | | | | |
|---------------------------------------|------------------------------------|---|------|------|------|-----------|------|------|------|------------|------|------|------|-----------|------|------|------|
| AM PEAK | Direction: | Southbound | | | | Westbound | | | | Northbound | | | | Eastbound | | | |
| | Roadway: | 10th St. | | | | H St. | | | | 10th St. | | | | H St. | | | |
| | Movement: | Right | Thru | Left | Peds | Right | Thru | Left | Peds | Right | Thru | Left | Peds | Right | Thru | Left | Peds |
| 6:00 AM to 6:15 AM | | 3 | 5 | 1 | 0 | 0 | 170 | 1 | 1 | 4 | 0 | 0 | 3 | 2 | 27 | 0 | 2 |
| 6:15 AM to 6:30 AM | | 3 | 2 | 1 | 0 | 0 | 203 | 2 | 1 | 2 | 0 | 3 | 2 | 2 | 34 | 0 | 3 |
| 6:30 AM to 6:45 AM | | 0 | 5 | 0 | 1 | 0 | 305 | 1 | 1 | 2 | 0 | 4 | 4 | 2 | 33 | 0 | 4 |
| 6:45 AM to 7:00 AM | | 2 | 7 | 2 | 0 | 0 | 331 | 6 | 1 | 2 | 0 | 7 | 3 | 2 | 38 | 0 | 3 |
| 7:00 AM to 7:15 AM | | 3 | 2 | 2 | 0 | 0 | 351 | 8 | 1 | 5 | 0 | 6 | 1 | 4 | 64 | 0 | 2 |
| 7:15 AM to 7:30 AM | | 1 | 4 | 2 | 0 | 0 | 405 | 4 | 1 | 3 | 0 | 3 | 2 | 7 | 64 | 0 | 9 |
| 7:30 AM to 7:45 AM | | 3 | 8 | 3 | 0 | 0 | 394 | 4 | 1 | 5 | 0 | 17 | 3 | 2 | 75 | 0 | 8 |
| 7:45 AM to 8:00 AM | | 1 | 13 | 3 | 0 | 0 | 474 | 0 | 0 | 4 | 0 | 10 | 3 | 5 | 71 | 0 | 9 |
| 8:00 AM to 8:15 AM | | 3 | 9 | 1 | 0 | 0 | 489 | 4 | 3 | 4 | 0 | 9 | 5 | 4 | 94 | 0 | 9 |
| 8:15 AM to 8:30 AM | | 2 | 11 | 2 | 3 | 0 | 450 | 3 | 13 | 1 | 0 | 23 | 5 | 9 | 90 | 0 | 7 |
| 8:30 AM to 8:45 AM | | 0 | 12 | 3 | 1 | 0 | 514 | 6 | 0 | 1 | 0 | 12 | 3 | 3 | 81 | 0 | 12 |
| 8:45 AM to 9:00 AM | | 4 | 10 | 1 | 0 | 0 | 532 | 1 | 2 | 4 | 0 | 16 | 2 | 7 | 81 | 0 | 11 |
| PM PEAK | Direction: | Southbound | | | | Westbound | | | | Northbound | | | | Eastbound | | | |
| | Roadway: | 10th St. | | | | H St. | | | | 10th St. | | | | H St. | | | |
| | Movement: | Right | Thru | Left | Peds | Right | Thru | Left | Peds | Right | Thru | Left | Peds | Right | Thru | Left | Peds |
| 4:00 PM to 4:15 PM | | 4 | 20 | 7 | 0 | 0 | 125 | 3 | 18 | 19 | 0 | 17 | 3 | 7 | 285 | 0 | 32 |
| 4:15 PM to 4:30 PM | | 6 | 14 | 9 | 1 | 0 | 119 | 8 | 14 | 13 | 0 | 21 | 2 | 11 | 296 | 0 | 35 |
| 4:30 PM to 4:45 PM | | 8 | 13 | 11 | 0 | 0 | 96 | 3 | 32 | 7 | 0 | 15 | 1 | 13 | 261 | 0 | 37 |
| 4:45 PM to 5:00 PM | | 3 | 15 | 7 | 0 | 0 | 127 | 5 | 27 | 9 | 0 | 16 | 3 | 12 | 290 | 0 | 21 |
| 5:00 PM to 5:15 PM | | 9 | 19 | 7 | 9 | 1 | 106 | 2 | 22 | 14 | 0 | 5 | 7 | 5 | 297 | 0 | 22 |
| 5:15 PM to 5:30 PM | | 5 | 16 | 4 | 5 | 0 | 97 | 3 | 15 | 10 | 0 | 10 | 4 | 9 | 279 | 0 | 23 |
| 5:30 PM to 5:45 PM | | 8 | 15 | 11 | 6 | 0 | 90 | 3 | 16 | 11 | 0 | 11 | 5 | 5 | 260 | 0 | 16 |
| 5:45 PM to 6:00 PM | | 4 | 13 | 5 | 1 | 0 | 95 | 2 | 10 | 8 | 0 | 12 | 4 | 9 | 302 | 0 | 30 |
| 6:00 PM to 6:15 PM | | 8 | 12 | 4 | 5 | 0 | 111 | 3 | 10 | 10 | 0 | 12 | 1 | 10 | 310 | 0 | 27 |
| 6:15 PM to 6:30 PM | | 3 | 11 | 4 | 3 | 0 | 85 | 6 | 9 | 6 | 0 | 7 | 3 | 13 | 282 | 0 | 25 |
| 6:30 PM to 6:45 PM | | 7 | 8 | 8 | 1 | 0 | 91 | 7 | 15 | 11 | 0 | 8 | 1 | 10 | 236 | 0 | 19 |
| 6:45 PM to 7:00 PM | | 5 | 6 | 6 | 5 | 0 | 84 | 5 | 9 | 14 | 0 | 7 | 0 | 10 | 199 | 0 | 9 |
| PEAK HOURS | Direction: | Southbound | | | | Westbound | | | | Northbound | | | | Eastbound | | | |
| | Roadway: | 10th St. | | | | H St. | | | | 10th St. | | | | H St. | | | |
| | Movement: | Right | Thru | Left | Peds | Right | Thru | Left | Peds | Right | Thru | Left | Peds | Right | Thru | Left | Peds |
| AM INTERSECTION PEAK HOUR | | | | | | | | | | | | | | | | | |
| 8:00 AM to 9:00 AM | | 9 | 42 | 7 | 4 | 0 | 1985 | 14 | 18 | 10 | 0 | 60 | 15 | 23 | 346 | 0 | 39 |
| PM INTERSECTION PEAK HOUR | | | | | | | | | | | | | | | | | |
| 4:00 PM to 5:00 PM | | 21 | 62 | 34 | 1 | 0 | 467 | 19 | 91 | 48 | 0 | 69 | 9 | 43 | 1132 | 0 | 125 |
| AM SYSTEM PEAK HOUR | | | | | | | | | | | | | | | | | |
| 8:00 AM to 9:00 AM | | 9 | 42 | 7 | 4 | 0 | 1985 | 14 | 18 | 10 | 0 | 60 | 15 | 23 | 346 | 0 | 39 |
| PM SYSTEM PEAK HOUR | | | | | | | | | | | | | | | | | |
| 4:00 PM to 5:00 PM | | 21 | 62 | 34 | 1 | 0 | 467 | 19 | 91 | 48 | 0 | 69 | 9 | 43 | 1132 | 0 | 125 |
| PEAK HOUR | FACTORS | Southbound | | | | Westbound | | | | Northbound | | | | Eastbound | | | |
| | | 10th St. | | | | H St. | | | | 10th St. | | | | H St. | | | |
| | | Right | Thru | Left | Peds | Right | Thru | Left | Peds | Right | Thru | Left | Peds | Right | Thru | Left | Peds |
| | AM PEAK HOUR | 0.56 | 0.88 | 0.58 | N/A | 0.00 | 0.93 | 0.58 | N/A | 0.63 | 0.00 | 0.65 | N/A | 0.64 | 0.92 | 0.00 | N/A |
| | PM PEAK HOUR | 0.66 | 0.78 | 0.77 | N/A | 0.00 | 0.92 | 0.59 | N/A | 0.63 | 0.00 | 0.82 | N/A | 0.83 | 0.96 | 0.00 | N/A |
| | Overall AM PEAK HOUR FACTOR | = 0.95 | | | | | | | | | | | | | | | |
| | Overall PM PEAK HOUR FACTOR | = 0.95 | | | | | | | | | | | | | | | |
| AM Period Intersection Volume: | | 5740 | | | | 5276 | | | | | | | | | | | |
| PM Period Intersection Volume: | | | | | | | | | | 5276 | | | | | | | |

Date of Counts: Wednesday, June 06, 2007
 AM Weather Conditions: Warm, Clear
 PM Weather Conditions: Warm, Clear

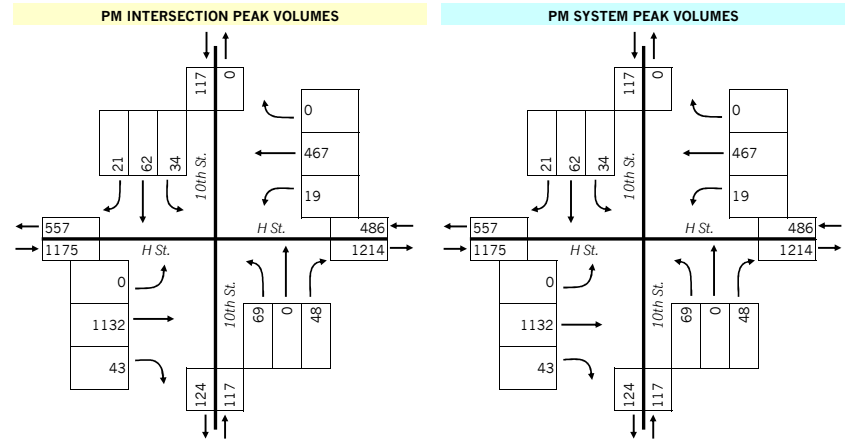
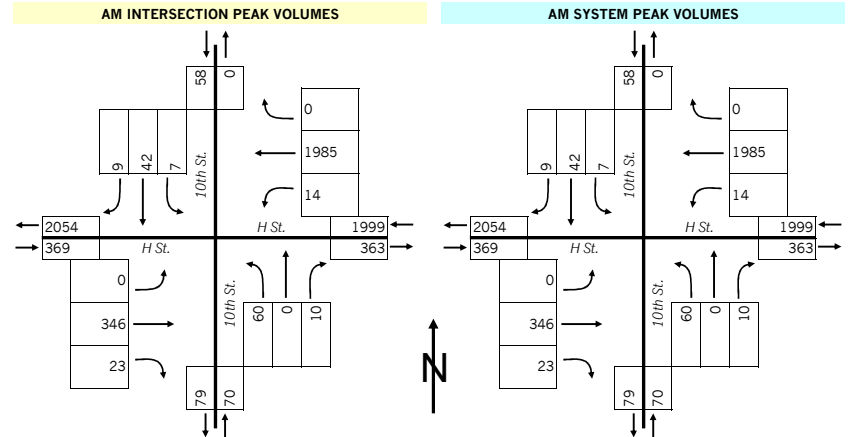

Gorove/Slade Associates

| | |
|------------------|-------------------------|
| Project Name | 8th Street at H Street |
| Project Number | 2117-001 |
| Project Location | DC |
| Data Source | Gorove/Slade Associates |

| Intersection: | | 10th Street Northeast at the alley behind the plaza on H St. between 8th and 10th St.'s Northeast | | | | | | | | | | | | | | | | | | | |
|---------------------------------------|-------------------|--|------|------|------|---------------------------------------|------|------|------|------------------------------------|------|------|------|-----------|------|------|------|--------|--|--|--|
| AM PEAK | Direction: | Southbound | | | | Westbound | | | | Northbound | | | | Eastbound | | | | | | | |
| | Roadway: | 10th St. | | | | One-Way | | | | 10th St. | | | | Alley | | | | | | | |
| | Movement: | Right | Thru | Left | Peds | Right | Thru | Left | Peds | Right | Thru | Left | Peds | Right | Thru | Left | Peds | | | | |
| 6:00 AM to 6:15 AM | | 0 | 7 | 0 | 1 | 0 | 0 | 0 | 0 | 0 | 3 | 0 | 0 | 0 | 0 | 0 | 1 | 0 | | | |
| 6:15 AM to 6:30 AM | | 0 | 5 | 0 | 3 | 0 | 0 | 0 | 2 | 0 | 5 | 0 | 0 | 0 | 0 | 0 | 0 | 3 | | | |
| 6:30 AM to 6:45 AM | | 0 | 9 | 0 | 1 | 0 | 0 | 0 | 8 | 0 | 6 | 0 | 1 | 1 | 0 | 0 | 4 | | | | |
| 6:45 AM to 7:00 AM | | 2 | 13 | 0 | 2 | 0 | 0 | 0 | 1 | 0 | 10 | 0 | 0 | 0 | 0 | 1 | 2 | | | | |
| 7:00 AM to 7:15 AM | | 0 | 10 | 0 | 0 | 0 | 0 | 0 | 2 | 0 | 6 | 0 | 0 | 0 | 0 | 0 | 1 | | | | |
| 7:15 AM to 7:30 AM | | 1 | 11 | 0 | 0 | 0 | 0 | 0 | 4 | 0 | 6 | 0 | 0 | 0 | 0 | 0 | 4 | | | | |
| 7:30 AM to 7:45 AM | | 0 | 10 | 0 | 0 | 0 | 0 | 0 | 1 | 0 | 17 | 1 | 2 | 2 | 0 | 1 | 6 | | | | |
| 7:45 AM to 8:00 AM | | 1 | 15 | 0 | 0 | 0 | 0 | 0 | 2 | 0 | 14 | 0 | 3 | 2 | 0 | 0 | 6 | | | | |
| 8:00 AM to 8:15 AM | | 0 | 15 | 0 | 0 | 0 | 0 | 0 | 5 | 0 | 13 | 1 | 3 | 2 | 0 | 1 | 17 | | | | |
| 8:15 AM to 8:30 AM | | 0 | 29 | 0 | 0 | 0 | 0 | 0 | 4 | 0 | 24 | 2 | 3 | 2 | 0 | 1 | 10 | | | | |
| 8:30 AM to 8:45 AM | | 2 | 23 | 0 | 0 | 0 | 0 | 0 | 3 | 0 | 16 | 1 | 0 | 0 | 0 | 0 | 21 | | | | |
| 8:45 AM to 9:00 AM | | 3 | 16 | 0 | 1 | 0 | 0 | 0 | 3 | 0 | 16 | 2 | 3 | 2 | 0 | 0 | 14 | | | | |
| PM PEAK | Direction: | Southbound | | | | Westbound | | | | Northbound | | | | Eastbound | | | | | | | |
| | Roadway: | 10th St. | | | | One-Way | | | | 10th St. | | | | Alley | | | | | | | |
| | Movement: | Right | Thru | Left | Peds | Right | Thru | Left | Peds | Right | Thru | Left | Peds | Right | Thru | Left | Peds | | | | |
| 4:00 PM to 4:15 PM | | 3 | 26 | 0 | 0 | 1 | 0 | 0 | 1 | 0 | 24 | 5 | 1 | 3 | 0 | 1 | 20 | | | | |
| 4:15 PM to 4:30 PM | | 4 | 29 | 0 | 0 | 0 | 0 | 0 | 10 | 0 | 29 | 2 | 2 | 3 | 0 | 5 | 16 | | | | |
| 4:30 PM to 4:45 PM | | 5 | 25 | 0 | 0 | 0 | 0 | 0 | 7 | 0 | 22 | 3 | 5 | 3 | 0 | 1 | 9 | | | | |
| 4:45 PM to 5:00 PM | | 2 | 27 | 0 | 2 | 0 | 0 | 0 | 5 | 0 | 19 | 0 | 1 | 3 | 0 | 0 | 18 | | | | |
| 5:00 PM to 5:15 PM | | 0 | 24 | 0 | 0 | 0 | 0 | 0 | 9 | 0 | 15 | 5 | 5 | 2 | 0 | 2 | 10 | | | | |
| 5:15 PM to 5:30 PM | | 1 | 24 | 0 | 0 | 0 | 0 | 0 | 3 | 0 | 14 | 0 | 2 | 4 | 0 | 3 | 7 | | | | |
| 5:30 PM to 5:45 PM | | 0 | 26 | 0 | 1 | 0 | 0 | 0 | 4 | 0 | 18 | 2 | 3 | 1 | 0 | 0 | 10 | | | | |
| 5:45 PM to 6:00 PM | | 1 | 25 | 0 | 3 | 0 | 0 | 0 | 3 | 0 | 17 | 1 | 0 | 0 | 0 | 0 | 12 | | | | |
| 6:00 PM to 6:15 PM | | 0 | 22 | 0 | 3 | 0 | 0 | 0 | 8 | 0 | 19 | 3 | 1 | 3 | 0 | 1 | 24 | | | | |
| 6:15 PM to 6:30 PM | | 1 | 26 | 0 | 1 | 0 | 0 | 0 | 5 | 0 | 6 | 2 | 4 | 3 | 0 | 3 | 15 | | | | |
| 6:30 PM to 6:45 PM | | 0 | 25 | 0 | 4 | 0 | 0 | 0 | 6 | 0 | 15 | 2 | 3 | 0 | 0 | 0 | 26 | | | | |
| 6:45 PM to 7:00 PM | | 4 | 11 | 0 | 1 | 0 | 0 | 0 | 6 | 0 | 15 | 0 | 2 | 3 | 0 | 2 | 10 | | | | |
| PEAK HOURS | | Southbound | | | | Westbound | | | | Northbound | | | | Eastbound | | | | | | | |
| Direction: | | 10th St. | | | | One-Way | | | | 10th St. | | | | Alley | | | | | | | |
| Roadway: | | 10th St. | | | | One-Way | | | | 10th St. | | | | Alley | | | | | | | |
| Movement: | | Right | Thru | Left | Peds | Right | Thru | Left | Peds | Right | Thru | Left | Peds | Right | Thru | Left | Peds | | | | |
| AM INTERSECTION PEAK HOUR | | | | | | | | | | | | | | | | | | | | | |
| 8:00 AM to 9:00 AM | | 5 | 83 | 0 | 1 | 0 | 0 | 0 | 15 | 0 | 69 | 6 | 9 | 6 | 0 | 2 | 62 | | | | |
| PM INTERSECTION PEAK HOUR | | | | | | | | | | | | | | | | | | | | | |
| 4:00 PM to 5:00 PM | | 14 | 107 | 0 | 2 | 1 | 0 | 0 | 23 | 0 | 94 | 10 | 9 | 12 | 0 | 7 | 63 | | | | |
| AM SYSTEM PEAK HOUR | | | | | | | | | | | | | | | | | | | | | |
| 8:00 AM to 9:00 AM | | 5 | 83 | 0 | 1 | 0 | 0 | 0 | 15 | 0 | 69 | 6 | 9 | 6 | 0 | 2 | 62 | | | | |
| PM SYSTEM PEAK HOUR | | | | | | | | | | | | | | | | | | | | | |
| 4:00 PM to 5:00 PM | | 14 | 107 | 0 | 2 | 1 | 0 | 0 | 23 | 0 | 94 | 10 | 9 | 12 | 0 | 7 | 63 | | | | |
| PEAK HOUR | | Southbound | | | | Westbound | | | | Northbound | | | | Eastbound | | | | | | | |
| FACTORS | | 10th St. | | | | One-Way | | | | 10th St. | | | | Alley | | | | | | | |
| AM PEAK HOUR | | 0.42 | 0.72 | 0.00 | N/A | 0.00 | 0.00 | 0.00 | N/A | 0.00 | 0.72 | 0.75 | N/A | 0.75 | 0.00 | 0.50 | N/A | | | | |
| PM PEAK HOUR | | 0.70 | 0.92 | 0.00 | N/A | 0.25 | 0.00 | 0.00 | N/A | 0.00 | 0.81 | 0.50 | N/A | 1.00 | 0.00 | 0.35 | N/A | | | | |
| Overall AM PEAK HOUR FACTOR | | = 0.74 | | | | | | | | Overall PM PEAK HOUR FACTOR | | | | | | | | = 0.85 | | | |
| AM Period Intersection Volume: | | 331 | | | | PM Period Intersection Volume: | | | | 596 | | | | | | | | | | | |

Date of Counts: Wednesday, June 06, 2007
 AM Weather Conditions: Warm, Clear PM Weather Conditions: Warm, Clear

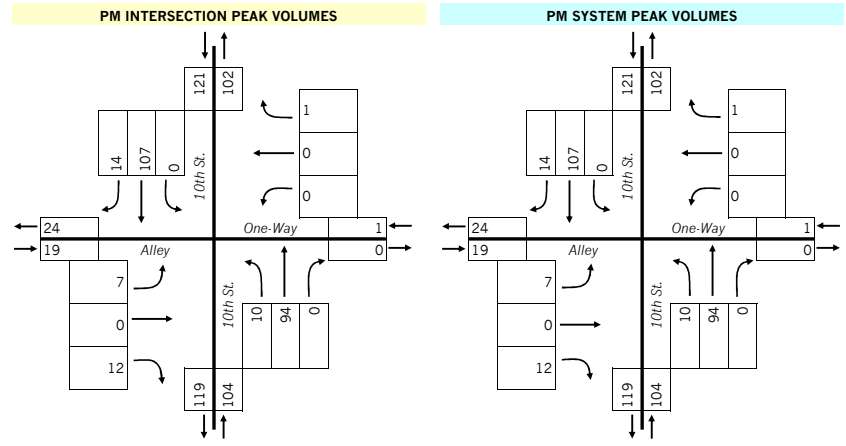
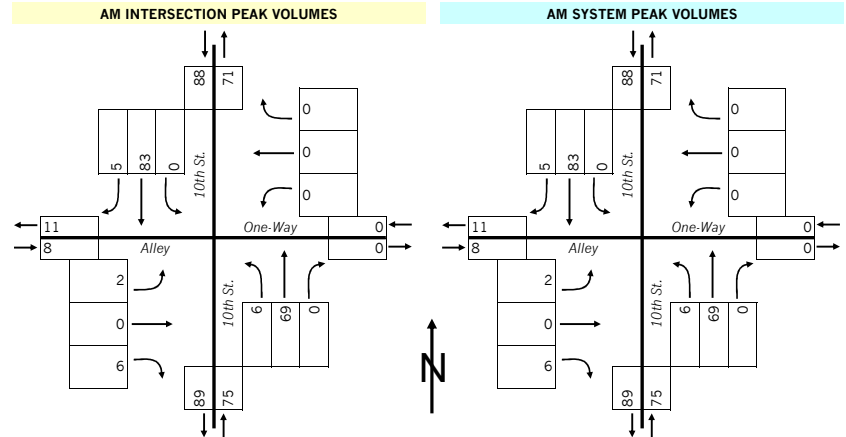

APPENDIX D
Capacity Analysis Worksheet

HCM Signalized Intersection Capacity Analysis
 1: H STREET & 8th STREET

AM Peak - Existing
 7/17/2007



| Movement | EBL | EBT | EBR | WBL | WBT | WBR | NBL | NBT | NBR | SBL | SBT | SBR |
|-----------------------------------|------|------|------|------|------|------|------|------|------|------|------|------|
| Lane Configurations | | ↑↑ | | | ↑↑ | | | ↑ | | | ↑↓ | |
| Ideal Flow (vphpl) | 1900 | 1900 | 1900 | 1900 | 1900 | 1900 | 1900 | 1900 | 1900 | 1900 | 1900 | 1900 |
| Total Lost time (s) | | 4.0 | | | 4.0 | | | 4.0 | | | 4.0 | |
| Lane Util. Factor | | 0.95 | | | 0.95 | | | 1.00 | | | 1.00 | |
| Fr _t | | 0.99 | | | 1.00 | | | 0.99 | | | 0.98 | |
| Fl _t Protected | | 1.00 | | | 1.00 | | | 1.00 | | | 1.00 | |
| Satd. Flow (prot) | | 3504 | | | 3530 | | | 1839 | | | 1824 | |
| Fl _t Permitted | | 1.00 | | | 1.00 | | | 1.00 | | | 0.88 | |
| Satd. Flow (perm) | | 3504 | | | 3530 | | | 1839 | | | 1620 | |
| Volume (vph) | 0 | 339 | 15 | 0 | 1557 | 29 | 0 | 186 | 13 | 16 | 179 | 25 |
| Peak-hour factor, PHF | 0.58 | 0.86 | 0.54 | 0.25 | 0.94 | 1.00 | 0.50 | 0.82 | 0.54 | 0.67 | 0.86 | 0.78 |
| Adj. Flow (vph) | 0 | 394 | 28 | 0 | 1656 | 29 | 0 | 227 | 24 | 24 | 208 | 32 |
| RTOR Reduction (vph) | 0 | 5 | 0 | 0 | 1 | 0 | 0 | 4 | 0 | 0 | 5 | 0 |
| Lane Group Flow (vph) | 0 | 417 | 0 | 0 | 1684 | 0 | 0 | 247 | 0 | 0 | 259 | 0 |
| Turn Type | | | | | | | | | | | Perm | |
| Protected Phases | | 4 | | | 8 | | | 2 | | | 6 | |
| Permitted Phases | | | | | | | | | | 6 | | |
| Actuated Green, G (s) | | 67.0 | | | 67.0 | | | 21.0 | | | 21.0 | |
| Effective Green, g (s) | | 69.0 | | | 69.0 | | | 23.0 | | | 23.0 | |
| Actuated g/C Ratio | | 0.69 | | | 0.69 | | | 0.23 | | | 0.23 | |
| Clearance Time (s) | | 6.0 | | | 6.0 | | | 6.0 | | | 6.0 | |
| Lane Grp Cap (vph) | | 2418 | | | 2436 | | | 423 | | | 373 | |
| v/s Ratio Prot | | 0.12 | | | 0.48 | | | 0.13 | | | | |
| v/s Ratio Perm | | | | | | | | | | | 0.16 | |
| v/c Ratio | | 0.17 | | | 0.69 | | | 0.58 | | | 0.70 | |
| Uniform Delay, d ₁ | | 5.5 | | | 9.2 | | | 34.2 | | | 35.3 | |
| Progression Factor | | 1.00 | | | 0.26 | | | 1.00 | | | 1.00 | |
| Incremental Delay, d ₂ | | 0.2 | | | 0.9 | | | 5.8 | | | 10.3 | |
| Delay (s) | | 5.6 | | | 3.3 | | | 40.0 | | | 45.5 | |
| Level of Service | | A | | | A | | | D | | | D | |
| Approach Delay (s) | | 5.6 | | | 3.3 | | | 40.0 | | | 45.5 | |
| Approach LOS | | A | | | A | | | D | | | D | |

| Intersection Summary | | | |
|-----------------------------------|-------|----------------------|-----|
| HCM Average Control Delay | 11.4 | HCM Level of Service | B |
| HCM Volume to Capacity ratio | 0.69 | | |
| Actuated Cycle Length (s) | 100.0 | Sum of lost time (s) | 8.0 |
| Intersection Capacity Utilization | 75.0% | ICU Level of Service | D |
| Analysis Period (min) | 15 | | |

c Critical Lane Group

HCM Signalized Intersection Capacity Analysis
2: H STREET & 9th STREET

AM Peak - Existing
7/17/2007



| Movement | EBL | EBT | EBR | WBL | WBT | WBR | NBL | NBT | NBR | SBL | SBT | SBR |
|-----------------------------------|------|------|------|------|-------|------|------|-------|------|------|------|------|
| Lane Configurations | | ↕↕ | | | ↕↕ | | | ↕ | | | ↕ | |
| Ideal Flow (vphpl) | 1900 | 1900 | 1900 | 1900 | 1900 | 1900 | 1900 | 1900 | 1900 | 1900 | 1900 | 1900 |
| Total Lost time (s) | | 4.0 | | | 4.0 | | | 4.0 | | | 4.0 | |
| Lane Util. Factor | | 0.95 | | | 0.95 | | | 1.00 | | | 1.00 | |
| Fr _t | | 0.99 | | | 0.99 | | | 0.96 | | | 0.96 | |
| Fl _t Protected | | 1.00 | | | 1.00 | | | 0.98 | | | 0.98 | |
| Satd. Flow (prot) | | 3511 | | | 3510 | | | 1752 | | | 1752 | |
| Fl _t Permitted | | 0.85 | | | 0.95 | | | 0.91 | | | 0.91 | |
| Satd. Flow (perm) | | 2974 | | | 3342 | | | 1632 | | | 1632 | |
| Volume (vph) | 7 | 342 | 12 | 5 | 1571 | 80 | 10 | 7 | 7 | 13 | 6 | 9 |
| Peak-hour factor, PHF | 0.44 | 0.93 | 0.75 | 0.42 | 0.89 | 0.80 | 0.63 | 0.58 | 0.58 | 0.81 | 0.50 | 0.75 |
| Adj. Flow (vph) | 16 | 368 | 16 | 12 | 1765 | 100 | 16 | 12 | 12 | 16 | 12 | 12 |
| RTOR Reduction (vph) | 0 | 3 | 0 | 0 | 4 | 0 | 0 | 9 | 0 | 0 | 9 | 0 |
| Lane Group Flow (vph) | 0 | 397 | 0 | 0 | 1873 | 0 | 0 | 31 | 0 | 0 | 31 | 0 |
| Turn Type | Perm | | Perm | | Perm | | Perm | | Perm | | Perm | |
| Protected Phases | | 4 | | | 8 | | | 2 | | | 6 | |
| Permitted Phases | 4 | | | 8 | | | 2 | | | 6 | | |
| Actuated Green, G (s) | | 65.0 | | | 65.0 | | | 24.0 | | | 24.0 | |
| Effective Green, g (s) | | 67.0 | | | 67.0 | | | 25.0 | | | 25.0 | |
| Actuated g/C Ratio | | 0.67 | | | 0.67 | | | 0.25 | | | 0.25 | |
| Clearance Time (s) | | 6.0 | | | 6.0 | | | 5.0 | | | 5.0 | |
| Lane Grp Cap (vph) | | 1993 | | | 2239 | | | 408 | | | 408 | |
| v/s Ratio Prot | | | | | | | | | | | | |
| v/s Ratio Perm | | 0.13 | | | c0.56 | | | c0.02 | | | 0.02 | |
| v/c Ratio | | 0.20 | | | 0.84 | | | 0.08 | | | 0.08 | |
| Uniform Delay, d ₁ | | 6.3 | | | 12.4 | | | 28.7 | | | 28.7 | |
| Progression Factor | | 0.58 | | | 0.39 | | | 1.00 | | | 1.00 | |
| Incremental Delay, d ₂ | | 0.2 | | | 2.8 | | | 0.4 | | | 0.4 | |
| Delay (s) | | 3.9 | | | 7.6 | | | 29.0 | | | 29.0 | |
| Level of Service | | A | | | A | | | C | | | C | |
| Approach Delay (s) | | 3.9 | | | 7.6 | | | 29.0 | | | 29.0 | |
| Approach LOS | | A | | | A | | | C | | | C | |

Intersection Summary

| | | | |
|-----------------------------------|-------|----------------------|-----|
| HCM Average Control Delay | 7.7 | HCM Level of Service | A |
| HCM Volume to Capacity ratio | 0.63 | | |
| Actuated Cycle Length (s) | 100.0 | Sum of lost time (s) | 8.0 |
| Intersection Capacity Utilization | 59.5% | ICU Level of Service | B |
| Analysis Period (min) | 15 | | |

c Critical Lane Group

HCM Signalized Intersection Capacity Analysis
 3: H STREET & 10th STREET

AM Peak - Existing
 7/17/2007

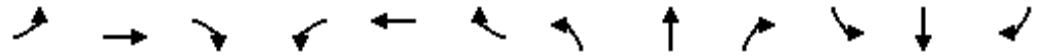

| Movement | EBL | EBT | EBR | WBL | WBT | WBR | NBL | NBT | NBR | SBL | SBT | SBR |
|-----------------------------------|------|------|------|------|-------|------|------|-------|------|------|------|------|
| Lane Configurations | | ↑↑ | | | ↑↑ | | | ↑↓ | | | ↑↓ | |
| Ideal Flow (vphpl) | 1900 | 1900 | 1900 | 1900 | 1900 | 1900 | 1900 | 1900 | 1900 | 1900 | 1900 | 1900 |
| Total Lost time (s) | | 4.0 | | | 4.0 | | | 4.0 | | | 4.0 | |
| Lane Util. Factor | | 0.95 | | | 0.95 | | | 1.00 | | | 1.00 | |
| Fr _t | | 0.99 | | | 1.00 | | | 0.98 | | | 0.97 | |
| Fl _t Protected | | 1.00 | | | 1.00 | | | 0.96 | | | 0.99 | |
| Satd. Flow (prot) | | 3493 | | | 3537 | | | 1751 | | | 1795 | |
| Fl _t Permitted | | 1.00 | | | 0.95 | | | 0.72 | | | 0.94 | |
| Satd. Flow (perm) | | 3493 | | | 3345 | | | 1323 | | | 1701 | |
| Volume (vph) | 0 | 346 | 23 | 14 | 1585 | 0 | 60 | 0 | 10 | 9 | 42 | 9 |
| Peak-hour factor, PHF | 0.90 | 0.92 | 0.64 | 0.58 | 0.93 | 0.92 | 0.65 | 0.90 | 0.63 | 0.58 | 0.88 | 0.56 |
| Adj. Flow (vph) | 0 | 376 | 36 | 24 | 1704 | 0 | 92 | 0 | 16 | 16 | 48 | 16 |
| RTOR Reduction (vph) | 0 | 7 | 0 | 0 | 0 | 0 | 0 | 6 | 0 | 0 | 9 | 0 |
| Lane Group Flow (vph) | 0 | 405 | 0 | 0 | 1728 | 0 | 0 | 102 | 0 | 0 | 71 | 0 |
| Turn Type | | | | Perm | | Perm | | | Perm | | | |
| Protected Phases | | 4 | | | 8 | | | 2 | | | 6 | |
| Permitted Phases | | | | 8 | | | 2 | | | 6 | | |
| Actuated Green, G (s) | | 67.0 | | | 67.0 | | | 21.0 | | | 21.0 | |
| Effective Green, g (s) | | 69.0 | | | 69.0 | | | 23.0 | | | 23.0 | |
| Actuated g/C Ratio | | 0.69 | | | 0.69 | | | 0.23 | | | 0.23 | |
| Clearance Time (s) | | 6.0 | | | 6.0 | | | 6.0 | | | 6.0 | |
| Lane Grp Cap (vph) | | 2410 | | | 2308 | | | 304 | | | 391 | |
| v/s Ratio Prot | | 0.12 | | | | | | | | | | |
| v/s Ratio Perm | | | | | c0.52 | | | c0.08 | | | 0.04 | |
| v/c Ratio | | 0.17 | | | 0.75 | | | 0.34 | | | 0.18 | |
| Uniform Delay, d ₁ | | 5.4 | | | 9.9 | | | 32.1 | | | 30.9 | |
| Progression Factor | | 0.47 | | | 1.00 | | | 1.00 | | | 1.00 | |
| Incremental Delay, d ₂ | | 0.1 | | | 2.3 | | | 3.0 | | | 1.0 | |
| Delay (s) | | 2.7 | | | 12.2 | | | 35.1 | | | 31.9 | |
| Level of Service | | A | | | B | | | D | | | C | |
| Approach Delay (s) | | 2.7 | | | 12.2 | | | 35.1 | | | 31.9 | |
| Approach LOS | | A | | | B | | | D | | | C | |

| Intersection Summary | | | |
|-----------------------------------|-------|----------------------|-----|
| HCM Average Control Delay | 12.3 | HCM Level of Service | B |
| HCM Volume to Capacity ratio | 0.65 | | |
| Actuated Cycle Length (s) | 100.0 | Sum of lost time (s) | 8.0 |
| Intersection Capacity Utilization | 70.9% | ICU Level of Service | C |
| Analysis Period (min) | 15 | | |

c Critical Lane Group

HCM Unsignalized Intersection Capacity Analysis
 4: G STREET & 10th STREET

AM Peak - Existing
 7/17/2007

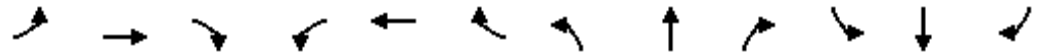

| Movement | EBL | EBT | EBR | WBL | WBT | WBR | NBL | NBT | NBR | SBL | SBT | SBR |
|-----------------------------------|-------|------|-------|----------------------|------|------|------|------|------|------|------|------|
| Lane Configurations | | | | | ↕ | | | ↕ | | | ↕ | |
| Sign Control | Stop | | | Stop | | | Stop | | | Stop | | |
| Volume (vph) | 0 | 0 | 0 | 5 | 235 | 19 | 33 | 55 | 0 | 0 | 73 | 24 |
| Peak Hour Factor | 0.90 | 0.90 | 0.90 | 0.63 | 0.92 | 0.68 | 0.83 | 0.63 | 0.90 | 0.90 | 0.79 | 0.75 |
| Hourly flow rate (vph) | 0 | 0 | 0 | 8 | 255 | 28 | 40 | 87 | 0 | 0 | 92 | 32 |
| Direction, Lane # | WB 1 | NB 1 | SB 1 | | | | | | | | | |
| Volume Total (vph) | 291 | 127 | 124 | | | | | | | | | |
| Volume Left (vph) | 8 | 40 | 0 | | | | | | | | | |
| Volume Right (vph) | 28 | 0 | 32 | | | | | | | | | |
| Hadj (s) | -0.02 | 0.10 | -0.12 | | | | | | | | | |
| Departure Headway (s) | 4.5 | 4.9 | 4.7 | | | | | | | | | |
| Degree Utilization, x | 0.36 | 0.17 | 0.16 | | | | | | | | | |
| Capacity (veh/h) | 761 | 694 | 718 | | | | | | | | | |
| Control Delay (s) | 10.1 | 8.9 | 8.5 | | | | | | | | | |
| Approach Delay (s) | 10.1 | 8.9 | 8.5 | | | | | | | | | |
| Approach LOS | B | A | A | | | | | | | | | |
| Intersection Summary | | | | | | | | | | | | |
| Delay | | | 9.4 | | | | | | | | | |
| HCM Level of Service | | | A | | | | | | | | | |
| Intersection Capacity Utilization | | | 31.8% | ICU Level of Service | | | | | | | | A |
| Analysis Period (min) | | | 15 | | | | | | | | | |

HCM Unsignalized Intersection Capacity Analysis
 5: G STREET & 8th STREET

AM Peak - Existing
 7/17/2007

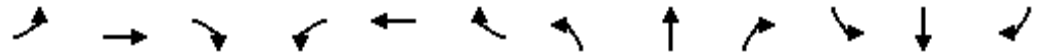

| Movement | EBL | EBT | EBR | WBL | WBT | WBR | NBL | NBT | NBR | SBL | SBT | SBR |
|-----------------------------------|-------|------|-------|----------------------|------|------|------|------|------|------|------|------|
| Lane Configurations | | | | | ↕ | | | ↕ | | | ↕ | |
| Sign Control | Stop | | | Stop | | | Stop | | | Stop | | |
| Volume (vph) | 0 | 0 | 0 | 11 | 277 | 57 | 47 | 244 | 0 | 0 | 180 | 19 |
| Peak Hour Factor | 0.90 | 0.90 | 0.90 | 0.39 | 0.95 | 0.89 | 0.78 | 0.91 | 0.92 | 0.92 | 0.87 | 0.68 |
| Hourly flow rate (vph) | 0 | 0 | 0 | 28 | 292 | 64 | 60 | 268 | 0 | 0 | 207 | 28 |
| Direction, Lane # | WB 1 | NB 1 | SB 1 | | | | | | | | | |
| Volume Total (vph) | 384 | 328 | 235 | | | | | | | | | |
| Volume Left (vph) | 28 | 60 | 0 | | | | | | | | | |
| Volume Right (vph) | 64 | 0 | 28 | | | | | | | | | |
| Hadj (s) | -0.05 | 0.07 | -0.04 | | | | | | | | | |
| Departure Headway (s) | 5.4 | 5.5 | 5.5 | | | | | | | | | |
| Degree Utilization, x | 0.57 | 0.50 | 0.36 | | | | | | | | | |
| Capacity (veh/h) | 635 | 620 | 609 | | | | | | | | | |
| Control Delay (s) | 15.3 | 13.8 | 11.6 | | | | | | | | | |
| Approach Delay (s) | 15.3 | 13.8 | 11.6 | | | | | | | | | |
| Approach LOS | C | B | B | | | | | | | | | |
| Intersection Summary | | | | | | | | | | | | |
| Delay | | | 13.9 | | | | | | | | | |
| HCM Level of Service | | | B | | | | | | | | | |
| Intersection Capacity Utilization | | | 54.7% | ICU Level of Service | | | | | | | | A |
| Analysis Period (min) | | | 15 | | | | | | | | | |

HCM Unsignalized Intersection Capacity Analysis
6: Alley Access East & 10th STREET

AM Peak - Existing
7/17/2007



| Movement | EBL | EBR | NBL | NBT | SBT | SBR |
|-----------------------------------|-------------|-------------|----------------------|------|------|------|
| Lane Configurations | | | | | | |
| Sign Control | Stop | | | Free | Free | |
| Grade | 0% | | | 0% | 0% | |
| Volume (veh/h) | 2 | 6 | 6 | 69 | 83 | 5 |
| Peak Hour Factor | 0.92 | 0.92 | 0.92 | 0.92 | 0.92 | 0.92 |
| Hourly flow rate (vph) | 2 | 7 | 7 | 75 | 90 | 5 |
| Pedestrians | | | | | | |
| Lane Width (ft) | | | | | | |
| Walking Speed (ft/s) | | | | | | |
| Percent Blockage | | | | | | |
| Right turn flare (veh) | | | | | | |
| Median type | None | | | | | |
| Median storage (veh) | | | | | | |
| Upstream signal (ft) | 199 | | | | | |
| pX, platoon unblocked | | | | | | |
| vC, conflicting volume | 181 | 93 | 96 | | | |
| vC1, stage 1 conf vol | | | | | | |
| vC2, stage 2 conf vol | | | | | | |
| vCu, unblocked vol | 181 | 93 | 96 | | | |
| tC, single (s) | 6.4 | 6.2 | 4.1 | | | |
| tC, 2 stage (s) | | | | | | |
| tF (s) | 3.5 | 3.3 | 2.2 | | | |
| p0 queue free % | 100 | 99 | 100 | | | |
| cM capacity (veh/h) | 805 | 964 | 1498 | | | |
| Direction, Lane # | EB 1 | NB 1 | SB 1 | | | |
| Volume Total | 9 | 82 | 96 | | | |
| Volume Left | 2 | 7 | 0 | | | |
| Volume Right | 7 | 0 | 5 | | | |
| cSH | 919 | 1498 | 1700 | | | |
| Volume to Capacity | 0.01 | 0.00 | 0.06 | | | |
| Queue Length 95th (ft) | 1 | 0 | 0 | | | |
| Control Delay (s) | 9.0 | 0.6 | 0.0 | | | |
| Lane LOS | A | A | | | | |
| Approach Delay (s) | 9.0 | 0.6 | 0.0 | | | |
| Approach LOS | A | | | | | |
| Intersection Summary | | | | | | |
| Average Delay | | | 0.7 | | | |
| Intersection Capacity Utilization | 18.6% | | ICU Level of Service | A | | |
| Analysis Period (min) | 15 | | | | | |

HCM Unsignalized Intersection Capacity Analysis
 7: Alley Access West & 8th STREET

AM Peak - Existing
 7/17/2007



| Movement | WBL | WBR | NBT | NBR | SBL | SBT |
|------------------------|------|------|------|------|------|------|
| Lane Configurations | ↔ | | ↑ | | | ↑ |
| Sign Control | Stop | | Free | | | Free |
| Grade | 0% | | 0% | | | 0% |
| Volume (veh/h) | 0 | 2 | 284 | 0 | 0 | 200 |
| Peak Hour Factor | 0.92 | 0.92 | 0.92 | 0.92 | 0.92 | 0.92 |
| Hourly flow rate (vph) | 0 | 2 | 309 | 0 | 0 | 217 |
| Pedestrians | | | | | | |
| Lane Width (ft) | | | | | | |
| Walking Speed (ft/s) | | | | | | |
| Percent Blockage | | | | | | |
| Right turn flare (veh) | | | | | | |
| Median type | None | | | | | |
| Median storage (veh) | | | | | | |
| Upstream signal (ft) | | | | | | 221 |
| pX, platoon unblocked | 0.90 | | | | | |
| vC, conflicting volume | 526 | 309 | | | 309 | |
| vC1, stage 1 conf vol | | | | | | |
| vC2, stage 2 conf vol | | | | | | |
| vCu, unblocked vol | 472 | 309 | | | 309 | |
| tC, single (s) | 6.4 | 6.2 | | | 4.1 | |
| tC, 2 stage (s) | | | | | | |
| tF (s) | 3.5 | 3.3 | | | 2.2 | |
| p0 queue free % | 100 | 100 | | | 100 | |
| cM capacity (veh/h) | 494 | 731 | | | 1252 | |

| Direction, Lane # | WB 1 | NB 1 | SB 1 |
|------------------------|------|------|------|
| Volume Total | 2 | 309 | 217 |
| Volume Left | 0 | 0 | 0 |
| Volume Right | 2 | 0 | 0 |
| cSH | 731 | 1700 | 1700 |
| Volume to Capacity | 0.00 | 0.18 | 0.13 |
| Queue Length 95th (ft) | 0 | 0 | 0 |
| Control Delay (s) | 9.9 | 0.0 | 0.0 |
| Lane LOS | A | | |
| Approach Delay (s) | 9.9 | 0.0 | 0.0 |
| Approach LOS | A | | |

| Intersection Summary | | | |
|-----------------------------------|--|-------|------------------------|
| Average Delay | | 0.0 | |
| Intersection Capacity Utilization | | 24.9% | ICU Level of Service A |
| Analysis Period (min) | | 15 | |

HCM Signalized Intersection Capacity Analysis
 1: H STREET & 8th STREET

PM Peak - Existing
 7/17/2007



| Movement | EBL | EBT | EBR | WBL | WBT | WBR | NBL | NBT | NBR | SBL | SBT | SBR |
|-----------------------------------|------|-------|------|------|------|------|------|------|------|------|-------|------|
| Lane Configurations | | ↕↕ | | | ↕↕ | | | ↕ | | | ↕↕ | |
| Ideal Flow (vphpl) | 1900 | 1900 | 1900 | 1900 | 1900 | 1900 | 1900 | 1900 | 1900 | 1900 | 1900 | 1900 |
| Total Lost time (s) | | 4.0 | | | 4.0 | | | 4.0 | | | 4.0 | |
| Lane Util. Factor | | 0.95 | | | 0.95 | | | 1.00 | | | 1.00 | |
| Fr _t | | 0.99 | | | 0.98 | | | 0.99 | | | 0.98 | |
| Fl _t Protected | | 1.00 | | | 1.00 | | | 1.00 | | | 0.99 | |
| Satd. Flow (prot) | | 3509 | | | 3479 | | | 1850 | | | 1807 | |
| Fl _t Permitted | | 0.89 | | | 1.00 | | | 1.00 | | | 0.69 | |
| Satd. Flow (perm) | | 3119 | | | 3479 | | | 1850 | | | 1251 | |
| Volume (vph) | 45 | 1127 | 29 | 0 | 470 | 52 | 0 | 243 | 11 | 46 | 176 | 44 |
| Peak-hour factor, PHF | 0.75 | 0.98 | 0.56 | 0.50 | 0.88 | 0.76 | 0.42 | 0.83 | 0.69 | 0.82 | 0.77 | 0.79 |
| Adj. Flow (vph) | 60 | 1150 | 52 | 0 | 534 | 68 | 0 | 293 | 16 | 56 | 229 | 56 |
| RTOR Reduction (vph) | 0 | 3 | 0 | 0 | 10 | 0 | 0 | 2 | 0 | 0 | 7 | 0 |
| Lane Group Flow (vph) | 0 | 1259 | 0 | 0 | 592 | 0 | 0 | 307 | 0 | 0 | 334 | 0 |
| Turn Type | Perm | | | | | | Perm | | | | | |
| Protected Phases | | 4 | | | 8 | | | 2 | | | 6 | |
| Permitted Phases | 4 | | | | | | | | | 6 | | |
| Actuated Green, G (s) | | 63.0 | | | 63.0 | | | 26.0 | | | 26.0 | |
| Effective Green, g (s) | | 64.0 | | | 64.0 | | | 28.0 | | | 28.0 | |
| Actuated g/C Ratio | | 0.64 | | | 0.64 | | | 0.28 | | | 0.28 | |
| Clearance Time (s) | | 5.0 | | | 5.0 | | | 6.0 | | | 6.0 | |
| Lane Grp Cap (vph) | | 1996 | | | 2227 | | | 518 | | | 350 | |
| v/s Ratio Prot | | | | | 0.17 | | | 0.17 | | | | |
| v/s Ratio Perm | | c0.40 | | | | | | | | | c0.27 | |
| v/c Ratio | | 0.63 | | | 0.27 | | | 0.59 | | | 0.95 | |
| Uniform Delay, d ₁ | | 10.9 | | | 7.8 | | | 31.1 | | | 35.4 | |
| Progression Factor | | 1.00 | | | 0.47 | | | 1.00 | | | 1.00 | |
| Incremental Delay, d ₂ | | 1.5 | | | 0.3 | | | 4.9 | | | 37.7 | |
| Delay (s) | | 12.4 | | | 3.9 | | | 36.0 | | | 73.1 | |
| Level of Service | | B | | | A | | | D | | | E | |
| Approach Delay (s) | | 12.4 | | | 3.9 | | | 36.0 | | | 73.1 | |
| Approach LOS | | B | | | A | | | D | | | E | |

| Intersection Summary | | | |
|-----------------------------------|-------|----------------------|-----|
| HCM Average Control Delay | 21.5 | HCM Level of Service | C |
| HCM Volume to Capacity ratio | 0.73 | | |
| Actuated Cycle Length (s) | 100.0 | Sum of lost time (s) | 8.0 |
| Intersection Capacity Utilization | 89.3% | ICU Level of Service | E |
| Analysis Period (min) | 15 | | |

c Critical Lane Group

HCM Signalized Intersection Capacity Analysis
2: H STREET & 9th STREET

PM Peak - Existing
7/17/2007



| Movement | EBL | EBT | EBR | WBL | WBT | WBR | NBL | NBT | NBR | SBL | SBT | SBR |
|-----------------------------------|------|-------|------|------|------|------|------|-------|------|------|------|------|
| Lane Configurations | | ↕↕ | | | ↕↕ | | | ↕ | | | ↕ | |
| Ideal Flow (vphpl) | 1900 | 1900 | 1900 | 1900 | 1900 | 1900 | 1900 | 1900 | 1900 | 1900 | 1900 | 1900 |
| Total Lost time (s) | | 4.0 | | | 4.0 | | | 4.0 | | | 4.0 | |
| Lane Util. Factor | | 0.95 | | | 0.95 | | | 1.00 | | | 1.00 | |
| Fr _t | | 1.00 | | | 0.98 | | | 0.94 | | | 0.95 | |
| Fl _t Protected | | 1.00 | | | 1.00 | | | 0.98 | | | 0.98 | |
| Satd. Flow (prot) | | 3521 | | | 3470 | | | 1726 | | | 1736 | |
| Fl _t Permitted | | 0.93 | | | 0.87 | | | 0.88 | | | 0.86 | |
| Satd. Flow (perm) | | 3278 | | | 3039 | | | 1553 | | | 1526 | |
| Volume (vph) | 15 | 1148 | 24 | 15 | 491 | 51 | 20 | 14 | 29 | 32 | 15 | 18 |
| Peak-hour factor, PHF | 0.54 | 0.93 | 0.67 | 0.63 | 0.90 | 0.67 | 0.56 | 0.58 | 0.66 | 0.89 | 0.75 | 0.56 |
| Adj. Flow (vph) | 28 | 1234 | 36 | 24 | 546 | 76 | 36 | 24 | 44 | 36 | 20 | 32 |
| RTOR Reduction (vph) | 0 | 2 | 0 | 0 | 10 | 0 | 0 | 26 | 0 | 0 | 20 | 0 |
| Lane Group Flow (vph) | 0 | 1296 | 0 | 0 | 636 | 0 | 0 | 78 | 0 | 0 | 68 | 0 |
| Turn Type | Perm | | Perm | | Perm | | Perm | | Perm | | Perm | |
| Protected Phases | | 4 | | | 8 | | | 2 | | | 6 | |
| Permitted Phases | 4 | | | 8 | | | 2 | | | 6 | | |
| Actuated Green, G (s) | | 66.0 | | | 66.0 | | | 23.0 | | | 23.0 | |
| Effective Green, g (s) | | 67.0 | | | 67.0 | | | 25.0 | | | 25.0 | |
| Actuated g/C Ratio | | 0.67 | | | 0.67 | | | 0.25 | | | 0.25 | |
| Clearance Time (s) | | 5.0 | | | 5.0 | | | 6.0 | | | 6.0 | |
| Lane Grp Cap (vph) | | 2196 | | | 2036 | | | 388 | | | 382 | |
| v/s Ratio Prot | | | | | | | | | | | | |
| v/s Ratio Perm | | c0.40 | | | 0.21 | | | c0.05 | | | 0.04 | |
| v/c Ratio | | 0.59 | | | 0.31 | | | 0.20 | | | 0.18 | |
| Uniform Delay, d ₁ | | 9.0 | | | 6.9 | | | 29.6 | | | 29.4 | |
| Progression Factor | | 0.35 | | | 0.69 | | | 1.00 | | | 1.00 | |
| Incremental Delay, d ₂ | | 0.9 | | | 0.4 | | | 1.2 | | | 1.0 | |
| Delay (s) | | 4.1 | | | 5.2 | | | 30.8 | | | 30.4 | |
| Level of Service | | A | | | A | | | C | | | C | |
| Approach Delay (s) | | 4.1 | | | 5.2 | | | 30.8 | | | 30.4 | |
| Approach LOS | | A | | | A | | | C | | | C | |

Intersection Summary

| | | | |
|-----------------------------------|-------|----------------------|-----|
| HCM Average Control Delay | 6.8 | HCM Level of Service | A |
| HCM Volume to Capacity ratio | 0.48 | | |
| Actuated Cycle Length (s) | 100.0 | Sum of lost time (s) | 8.0 |
| Intersection Capacity Utilization | 55.7% | ICU Level of Service | B |
| Analysis Period (min) | 15 | | |

c Critical Lane Group

HCM Signalized Intersection Capacity Analysis
 3: H STREET & 10th STREET

PM Peak - Existing
 7/17/2007

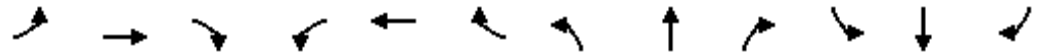

| Movement | EBL | EBT | EBR | WBL | WBT | WBR | NBL | NBT | NBR | SBL | SBT | SBR |
|------------------------|------|-------|------|------|------|------|------|-------|------|------|------|------|
| Lane Configurations | | ↑↑ | | | ↑↑ | | | ↑↓ | | | ↑↓ | |
| Ideal Flow (vphpl) | 1900 | 1900 | 1900 | 1900 | 1900 | 1900 | 1900 | 1900 | 1900 | 1900 | 1900 | 1900 |
| Total Lost time (s) | | 4.0 | | | 4.0 | | | 4.0 | | | 4.0 | |
| Lane Util. Factor | | 0.95 | | | 0.95 | | | 1.00 | | | 1.00 | |
| Frt | | 0.99 | | | 1.00 | | | 0.94 | | | 0.97 | |
| Flt Protected | | 1.00 | | | 1.00 | | | 0.97 | | | 0.99 | |
| Satd. Flow (prot) | | 3517 | | | 3529 | | | 1699 | | | 1785 | |
| Flt Permitted | | 1.00 | | | 0.83 | | | 0.70 | | | 0.88 | |
| Satd. Flow (perm) | | 3517 | | | 2950 | | | 1228 | | | 1589 | |
| Volume (vph) | 0 | 1132 | 43 | 19 | 467 | 0 | 69 | 0 | 48 | 34 | 62 | 21 |
| Peak-hour factor, PHF | 0.25 | 0.96 | 0.83 | 0.59 | 0.92 | 0.25 | 0.82 | 0.25 | 0.63 | 0.77 | 0.78 | 0.66 |
| Adj. Flow (vph) | 0 | 1179 | 52 | 32 | 508 | 0 | 84 | 0 | 76 | 44 | 79 | 32 |
| RTOR Reduction (vph) | 0 | 3 | 0 | 0 | 0 | 0 | 0 | 33 | 0 | 0 | 9 | 0 |
| Lane Group Flow (vph) | 0 | 1228 | 0 | 0 | 540 | 0 | 0 | 127 | 0 | 0 | 146 | 0 |
| Turn Type | | | | Perm | | Perm | | | Perm | | | |
| Protected Phases | | 4 | | | 8 | | | 2 | | | 6 | |
| Permitted Phases | | | | 8 | | | 2 | | | 6 | | |
| Actuated Green, G (s) | | 69.0 | | | 69.0 | | | 20.0 | | | 20.0 | |
| Effective Green, g (s) | | 70.0 | | | 70.0 | | | 22.0 | | | 22.0 | |
| Actuated g/C Ratio | | 0.70 | | | 0.70 | | | 0.22 | | | 0.22 | |
| Clearance Time (s) | | 5.0 | | | 5.0 | | | 6.0 | | | 6.0 | |
| Lane Grp Cap (vph) | | 2462 | | | 2065 | | | 270 | | | 350 | |
| v/s Ratio Prot | | c0.35 | | | | | | | | | | |
| v/s Ratio Perm | | | | | 0.18 | | | c0.10 | | | 0.09 | |
| v/c Ratio | | 0.50 | | | 0.26 | | | 0.47 | | | 0.42 | |
| Uniform Delay, d1 | | 6.9 | | | 5.5 | | | 33.9 | | | 33.5 | |
| Progression Factor | | 0.36 | | | 1.00 | | | 1.00 | | | 1.00 | |
| Incremental Delay, d2 | | 0.6 | | | 0.3 | | | 5.8 | | | 3.6 | |
| Delay (s) | | 3.1 | | | 5.8 | | | 39.7 | | | 37.1 | |
| Level of Service | | A | | | A | | | D | | | D | |
| Approach Delay (s) | | 3.1 | | | 5.8 | | | 39.7 | | | 37.1 | |
| Approach LOS | | A | | | A | | | D | | | D | |

| Intersection Summary | | | |
|-----------------------------------|-------|----------------------|-----|
| HCM Average Control Delay | 9.1 | HCM Level of Service | A |
| HCM Volume to Capacity ratio | 0.49 | | |
| Actuated Cycle Length (s) | 100.0 | Sum of lost time (s) | 8.0 |
| Intersection Capacity Utilization | 52.2% | ICU Level of Service | A |
| Analysis Period (min) | 15 | | |

c Critical Lane Group

HCM Unsignalized Intersection Capacity Analysis
 4: G STREET & 10th STREET

PM Peak - Existing
 7/17/2007

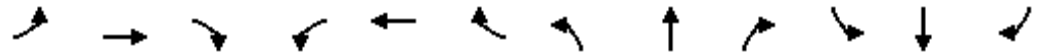

| Movement | EBL | EBT | EBR | WBL | WBT | WBR | NBL | NBT | NBR | SBL | SBT | SBR |
|-----------------------------------|-------|------|-------|----------------------|------|------|------|------|------|------|------|------|
| Lane Configurations | | | | | ↕ | | | ↕ | | | ↕ | |
| Sign Control | Stop | | | Stop | | | Stop | | | Stop | | |
| Volume (vph) | 0 | 0 | 0 | 6 | 75 | 18 | 17 | 84 | 0 | 0 | 94 | 18 |
| Peak Hour Factor | 0.25 | 0.25 | 0.25 | 0.38 | 0.78 | 0.75 | 0.71 | 0.81 | 0.25 | 0.25 | 0.90 | 0.90 |
| Hourly flow rate (vph) | 0 | 0 | 0 | 16 | 96 | 24 | 24 | 104 | 0 | 0 | 104 | 20 |
| Direction, Lane # | WB 1 | NB 1 | SB 1 | | | | | | | | | |
| Volume Total (vph) | 136 | 128 | 124 | | | | | | | | | |
| Volume Left (vph) | 16 | 24 | 0 | | | | | | | | | |
| Volume Right (vph) | 24 | 0 | 20 | | | | | | | | | |
| Hadj (s) | -0.05 | 0.07 | -0.06 | | | | | | | | | |
| Departure Headway (s) | 4.4 | 4.4 | 4.3 | | | | | | | | | |
| Degree Utilization, x | 0.17 | 0.16 | 0.15 | | | | | | | | | |
| Capacity (veh/h) | 763 | 780 | 797 | | | | | | | | | |
| Control Delay (s) | 8.3 | 8.3 | 8.1 | | | | | | | | | |
| Approach Delay (s) | 8.3 | 8.3 | 8.1 | | | | | | | | | |
| Approach LOS | A | A | A | | | | | | | | | |
| Intersection Summary | | | | | | | | | | | | |
| Delay | | | 8.2 | | | | | | | | | |
| HCM Level of Service | | | A | | | | | | | | | |
| Intersection Capacity Utilization | | | 24.1% | ICU Level of Service | | | | | | | | A |
| Analysis Period (min) | | | 15 | | | | | | | | | |

HCM Unsignalized Intersection Capacity Analysis
 5: G STREET & 8th STREET

PM Peak - Existing
 7/17/2007

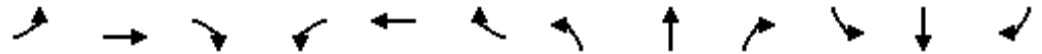

| Movement | EBL | EBT | EBR | WBL | WBT | WBR | NBL | NBT | NBR | SBL | SBT | SBR |
|------------------------|------|------|------|------|------|------|------|------|------|------|------|------|
| Lane Configurations | | | | | ↕ | | | ↕ | | | ↕ | |
| Sign Control | Stop | | | Stop | | | Stop | | | Stop | | |
| Volume (vph) | 0 | 0 | 0 | 7 | 86 | 48 | 27 | 223 | 0 | 0 | 195 | 8 |
| Peak Hour Factor | 0.25 | 0.25 | 0.25 | 0.58 | 0.74 | 0.71 | 0.75 | 0.94 | 0.25 | 0.25 | 0.90 | 0.40 |
| Hourly flow rate (vph) | 0 | 0 | 0 | 12 | 116 | 68 | 36 | 237 | 0 | 0 | 217 | 20 |

| Direction, Lane # | WB 1 | NB 1 | SB 1 |
|-----------------------|-------|------|-------|
| Volume Total (vph) | 196 | 273 | 237 |
| Volume Left (vph) | 12 | 36 | 0 |
| Volume Right (vph) | 68 | 0 | 20 |
| Hadj (s) | -0.16 | 0.06 | -0.02 |
| Departure Headway (s) | 5.0 | 4.8 | 4.7 |
| Degree Utilization, x | 0.27 | 0.36 | 0.31 |
| Capacity (veh/h) | 669 | 722 | 720 |
| Control Delay (s) | 9.8 | 10.5 | 9.9 |
| Approach Delay (s) | 9.8 | 10.5 | 9.9 |
| Approach LOS | A | B | A |

| Intersection Summary | | |
|-----------------------------------|-------|------------------------|
| Delay | | 10.1 |
| HCM Level of Service | | B |
| Intersection Capacity Utilization | 41.8% | ICU Level of Service A |
| Analysis Period (min) | | 15 |

HCM Unsignalized Intersection Capacity Analysis
6: Alley Access East & 10th STREET

PM Peak - Existing
7/17/2007



| Movement | EBL | EBR | NBL | NBT | SBT | SBR |
|-----------------------------------|-------------|-------------|-------------|----------------------|------|------|
| Lane Configurations | | | | | | |
| Sign Control | Stop | | | Free | Free | |
| Grade | 0% | | | 0% | 0% | |
| Volume (veh/h) | 2 | 6 | 6 | 69 | 83 | 5 |
| Peak Hour Factor | 0.92 | 0.92 | 0.92 | 0.92 | 0.92 | 0.92 |
| Hourly flow rate (vph) | 2 | 7 | 7 | 75 | 90 | 5 |
| Pedestrians | | | | | | |
| Lane Width (ft) | | | | | | |
| Walking Speed (ft/s) | | | | | | |
| Percent Blockage | | | | | | |
| Right turn flare (veh) | | | | | | |
| Median type | None | | | | | |
| Median storage (veh) | | | | | | |
| Upstream signal (ft) | | | | | 199 | |
| pX, platoon unblocked | | | | | | |
| vC, conflicting volume | 181 | 93 | 96 | | | |
| vC1, stage 1 conf vol | | | | | | |
| vC2, stage 2 conf vol | | | | | | |
| vCu, unblocked vol | 181 | 93 | 96 | | | |
| tC, single (s) | 6.4 | 6.2 | 4.1 | | | |
| tC, 2 stage (s) | | | | | | |
| tF (s) | 3.5 | 3.3 | 2.2 | | | |
| p0 queue free % | 100 | 99 | 100 | | | |
| cM capacity (veh/h) | 805 | 964 | 1498 | | | |
| Direction, Lane # | EB 1 | NB 1 | SB 1 | | | |
| Volume Total | 9 | 82 | 96 | | | |
| Volume Left | 2 | 7 | 0 | | | |
| Volume Right | 7 | 0 | 5 | | | |
| cSH | 919 | 1498 | 1700 | | | |
| Volume to Capacity | 0.01 | 0.00 | 0.06 | | | |
| Queue Length 95th (ft) | 1 | 0 | 0 | | | |
| Control Delay (s) | 9.0 | 0.6 | 0.0 | | | |
| Lane LOS | A | A | | | | |
| Approach Delay (s) | 9.0 | 0.6 | 0.0 | | | |
| Approach LOS | A | | | | | |
| Intersection Summary | | | | | | |
| Average Delay | | | 0.7 | | | |
| Intersection Capacity Utilization | | 18.6% | | ICU Level of Service | | A |
| Analysis Period (min) | | | 15 | | | |

HCM Unsignalized Intersection Capacity Analysis
 7: Alley Access West & 8th STREET

PM Peak - Existing
 7/17/2007



| Movement | WBL | WBR | NBT | NBR | SBL | SBT |
|-----------------------------------|-------------|-------------|-------------|----------------------|------|------|
| Lane Configurations | ↔ | | ↑ | | | ↑ |
| Sign Control | Stop | | Free | | | Free |
| Grade | 0% | | 0% | | | 0% |
| Volume (veh/h) | 0 | 4 | 272 | 0 | 0 | 212 |
| Peak Hour Factor | 0.92 | 0.92 | 0.92 | 0.92 | 0.92 | 0.92 |
| Hourly flow rate (vph) | 0 | 4 | 296 | 0 | 0 | 230 |
| Pedestrians | | | | | | |
| Lane Width (ft) | | | | | | |
| Walking Speed (ft/s) | | | | | | |
| Percent Blockage | | | | | | |
| Right turn flare (veh) | | | | | | |
| Median type | None | | | | | |
| Median storage (veh) | | | | | | |
| Upstream signal (ft) | 221 | | | | | |
| pX, platoon unblocked | | | | | | |
| vC, conflicting volume | 526 | 296 | | | 296 | |
| vC1, stage 1 conf vol | | | | | | |
| vC2, stage 2 conf vol | | | | | | |
| vCu, unblocked vol | 526 | 296 | | | 296 | |
| tC, single (s) | 6.4 | 6.2 | | | 4.1 | |
| tC, 2 stage (s) | | | | | | |
| tF (s) | 3.5 | 3.3 | | | 2.2 | |
| p0 queue free % | 100 | 99 | | | 100 | |
| cM capacity (veh/h) | 512 | 744 | | | 1266 | |
| Direction, Lane # | WB 1 | NB 1 | SB 1 | | | |
| Volume Total | 4 | 296 | 230 | | | |
| Volume Left | 0 | 0 | 0 | | | |
| Volume Right | 4 | 0 | 0 | | | |
| cSH | 744 | 1700 | 1700 | | | |
| Volume to Capacity | 0.01 | 0.17 | 0.14 | | | |
| Queue Length 95th (ft) | 0 | 0 | 0 | | | |
| Control Delay (s) | 9.9 | 0.0 | 0.0 | | | |
| Lane LOS | A | | | | | |
| Approach Delay (s) | 9.9 | 0.0 | 0.0 | | | |
| Approach LOS | A | | | | | |
| Intersection Summary | | | | | | |
| Average Delay | | | 0.1 | | | |
| Intersection Capacity Utilization | | | 24.3% | ICU Level of Service | A | |
| Analysis Period (min) | | | 15 | | | |

HCM Signalized Intersection Capacity Analysis
1: H STREET & 8th STREET

AM Peak - Background
7/17/2007



| Movement | EBL | EBT | EBR | WBL | WBT | WBR | NBL | NBT | NBR | SBL | SBT | SBR |
|------------------------|------|------|------|------|-------|------|------|------|------|------|-------|------|
| Lane Configurations | | ↑↑ | | | ↑↑ | | | ↑ | | | ↑↓ | |
| Ideal Flow (vphpl) | 1900 | 1900 | 1900 | 1900 | 1900 | 1900 | 1900 | 1900 | 1900 | 1900 | 1900 | 1900 |
| Total Lost time (s) | | 4.0 | | | 4.0 | | | 4.0 | | | 4.0 | |
| Lane Util. Factor | | 0.95 | | | 0.95 | | | 1.00 | | | 1.00 | |
| Frt | | 0.99 | | | 1.00 | | | 0.99 | | | 0.98 | |
| Flt Protected | | 1.00 | | | 1.00 | | | 1.00 | | | 1.00 | |
| Satd. Flow (prot) | | 3510 | | | 3531 | | | 1839 | | | 1824 | |
| Flt Permitted | | 1.00 | | | 1.00 | | | 1.00 | | | 0.88 | |
| Satd. Flow (perm) | | 3510 | | | 3531 | | | 1839 | | | 1620 | |
| Volume (vph) | 0 | 420 | 15 | 0 | 1766 | 29 | 0 | 186 | 13 | 16 | 179 | 25 |
| Peak-hour factor, PHF | 0.58 | 0.86 | 0.54 | 0.25 | 0.94 | 1.00 | 0.50 | 0.82 | 0.54 | 0.67 | 0.86 | 0.78 |
| Adj. Flow (vph) | 0 | 488 | 28 | 0 | 1879 | 29 | 0 | 227 | 24 | 24 | 208 | 32 |
| RTOR Reduction (vph) | 0 | 4 | 0 | 0 | 1 | 0 | 0 | 4 | 0 | 0 | 5 | 0 |
| Lane Group Flow (vph) | 0 | 512 | 0 | 0 | 1907 | 0 | 0 | 247 | 0 | 0 | 259 | 0 |
| Turn Type | | | | | | | | | | | Perm | |
| Protected Phases | | 4 | | | 8 | | | 2 | | | 6 | |
| Permitted Phases | | | | | | | | | | 6 | | |
| Actuated Green, G (s) | | 67.0 | | | 67.0 | | | 21.0 | | | 21.0 | |
| Effective Green, g (s) | | 69.0 | | | 69.0 | | | 23.0 | | | 23.0 | |
| Actuated g/C Ratio | | 0.69 | | | 0.69 | | | 0.23 | | | 0.23 | |
| Clearance Time (s) | | 6.0 | | | 6.0 | | | 6.0 | | | 6.0 | |
| Lane Grp Cap (vph) | | 2422 | | | 2436 | | | 423 | | | 373 | |
| v/s Ratio Prot | | 0.15 | | | c0.54 | | | 0.13 | | | | |
| v/s Ratio Perm | | | | | | | | | | | c0.16 | |
| v/c Ratio | | 0.21 | | | 0.78 | | | 0.58 | | | 0.70 | |
| Uniform Delay, d1 | | 5.6 | | | 10.4 | | | 34.2 | | | 35.3 | |
| Progression Factor | | 1.00 | | | 0.26 | | | 1.00 | | | 1.00 | |
| Incremental Delay, d2 | | 0.2 | | | 1.0 | | | 5.8 | | | 10.3 | |
| Delay (s) | | 5.8 | | | 3.7 | | | 40.0 | | | 45.5 | |
| Level of Service | | A | | | A | | | D | | | D | |
| Approach Delay (s) | | 5.8 | | | 3.7 | | | 40.0 | | | 45.5 | |
| Approach LOS | | A | | | A | | | D | | | D | |

Intersection Summary

| | | | |
|-----------------------------------|-------|----------------------|-----|
| HCM Average Control Delay | 10.9 | HCM Level of Service | B |
| HCM Volume to Capacity ratio | 0.76 | | |
| Actuated Cycle Length (s) | 100.0 | Sum of lost time (s) | 8.0 |
| Intersection Capacity Utilization | 80.8% | ICU Level of Service | D |
| Analysis Period (min) | 15 | | |

c Critical Lane Group

HCM Signalized Intersection Capacity Analysis
2: H STREET & 9th STREET

AM Peak - Background
7/17/2007



| Movement | EBL | EBT | EBR | WBL | WBT | WBR | NBL | NBT | NBR | SBL | SBT | SBR |
|------------------------|------|------|------|------|------|------|------|------|------|------|------|------|
| Lane Configurations | | ↕↕ | | | ↕↕ | | | ↕ | | | ↕ | |
| Ideal Flow (vphpl) | 1900 | 1900 | 1900 | 1900 | 1900 | 1900 | 1900 | 1900 | 1900 | 1900 | 1900 | 1900 |
| Total Lost time (s) | | 4.0 | | | 4.0 | | | 4.0 | | | 4.0 | |
| Lane Util. Factor | | 0.95 | | | 0.95 | | | 1.00 | | | 1.00 | |
| Frt | | 1.00 | | | 0.99 | | | 0.96 | | | 0.96 | |
| Flt Protected | | 1.00 | | | 1.00 | | | 0.98 | | | 0.98 | |
| Satd. Flow (prot) | | 3516 | | | 3513 | | | 1752 | | | 1752 | |
| Flt Permitted | | 0.79 | | | 0.95 | | | 0.91 | | | 0.91 | |
| Satd. Flow (perm) | | 2779 | | | 3344 | | | 1632 | | | 1632 | |
| Volume (vph) | 7 | 423 | 12 | 5 | 1782 | 80 | 10 | 7 | 7 | 13 | 6 | 9 |
| Peak-hour factor, PHF | 0.44 | 0.93 | 0.75 | 0.42 | 0.89 | 0.80 | 0.63 | 0.58 | 0.58 | 0.81 | 0.50 | 0.75 |
| Adj. Flow (vph) | 16 | 455 | 16 | 12 | 2002 | 100 | 16 | 12 | 12 | 16 | 12 | 12 |
| RTOR Reduction (vph) | 0 | 2 | 0 | 0 | 4 | 0 | 0 | 9 | 0 | 0 | 9 | 0 |
| Lane Group Flow (vph) | 0 | 485 | 0 | 0 | 2110 | 0 | 0 | 31 | 0 | 0 | 31 | 0 |
| Turn Type | Perm | | | Perm | | | Perm | | | Perm | | |
| Protected Phases | | 4 | | | 8 | | | 2 | | | 6 | |
| Permitted Phases | 4 | | | 8 | | | 2 | | | 6 | | |
| Actuated Green, G (s) | | 65.0 | | | 65.0 | | | 24.0 | | | 24.0 | |
| Effective Green, g (s) | | 67.0 | | | 67.0 | | | 25.0 | | | 25.0 | |
| Actuated g/C Ratio | | 0.67 | | | 0.67 | | | 0.25 | | | 0.25 | |
| Clearance Time (s) | | 6.0 | | | 6.0 | | | 5.0 | | | 5.0 | |
| Lane Grp Cap (vph) | | 1862 | | | 2240 | | | 408 | | | 408 | |
| v/s Ratio Prot | | | | | | | | | | | | |
| v/s Ratio Perm | | 0.17 | | | 0.63 | | | 0.02 | | | 0.02 | |
| v/c Ratio | | 0.26 | | | 0.94 | | | 0.08 | | | 0.08 | |
| Uniform Delay, d1 | | 6.6 | | | 14.8 | | | 28.7 | | | 28.7 | |
| Progression Factor | | 0.53 | | | 0.38 | | | 1.00 | | | 1.00 | |
| Incremental Delay, d2 | | 0.3 | | | 6.2 | | | 0.4 | | | 0.4 | |
| Delay (s) | | 3.8 | | | 11.8 | | | 29.0 | | | 29.0 | |
| Level of Service | | A | | | B | | | C | | | C | |
| Approach Delay (s) | | 3.8 | | | 11.8 | | | 29.0 | | | 29.0 | |
| Approach LOS | | A | | | B | | | C | | | C | |

| Intersection Summary | | | |
|-----------------------------------|-------|----------------------|-----|
| HCM Average Control Delay | 10.8 | HCM Level of Service | B |
| HCM Volume to Capacity ratio | 0.71 | | |
| Actuated Cycle Length (s) | 100.0 | Sum of lost time (s) | 8.0 |
| Intersection Capacity Utilization | 65.3% | ICU Level of Service | C |
| Analysis Period (min) | 15 | | |

c Critical Lane Group

HCM Signalized Intersection Capacity Analysis
 3: H STREET & 10th STREET

AM Peak - Background
 7/17/2007

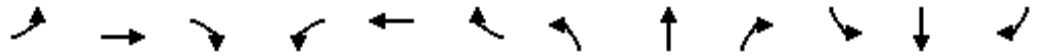

| Movement | EBL | EBT | EBR | WBL | WBT | WBR | NBL | NBT | NBR | SBL | SBT | SBR |
|-----------------------------------|------|------|------|------|-------|------|------|-------|------|------|------|------|
| Lane Configurations | | ↑↑ | | | ↑↑ | | | ↑↓ | | | ↑↓ | |
| Ideal Flow (vphpl) | 1900 | 1900 | 1900 | 1900 | 1900 | 1900 | 1900 | 1900 | 1900 | 1900 | 1900 | 1900 |
| Total Lost time (s) | | 4.0 | | | 4.0 | | | 4.0 | | | 4.0 | |
| Lane Util. Factor | | 0.95 | | | 0.95 | | | 1.00 | | | 1.00 | |
| Fr _t | | 0.99 | | | 1.00 | | | 0.98 | | | 0.97 | |
| Fl _t Protected | | 1.00 | | | 1.00 | | | 0.96 | | | 0.99 | |
| Satd. Flow (prot) | | 3501 | | | 3537 | | | 1751 | | | 1796 | |
| Fl _t Permitted | | 1.00 | | | 0.94 | | | 0.73 | | | 0.95 | |
| Satd. Flow (perm) | | 3501 | | | 3343 | | | 1337 | | | 1727 | |
| Volume (vph) | 0 | 428 | 23 | 14 | 1798 | 0 | 60 | 0 | 10 | 7 | 42 | 9 |
| Peak-hour factor, PHF | 0.92 | 0.92 | 0.64 | 0.58 | 0.93 | 0.92 | 0.65 | 0.90 | 0.63 | 0.58 | 0.88 | 0.56 |
| Adj. Flow (vph) | 0 | 465 | 36 | 24 | 1933 | 0 | 92 | 0 | 16 | 12 | 48 | 16 |
| RTOR Reduction (vph) | 0 | 6 | 0 | 0 | 0 | 0 | 0 | 6 | 0 | 0 | 9 | 0 |
| Lane Group Flow (vph) | 0 | 495 | 0 | 0 | 1957 | 0 | 0 | 102 | 0 | 0 | 67 | 0 |
| Turn Type | | | | Perm | | Perm | | | Perm | | | |
| Protected Phases | | 4 | | | 8 | | | 2 | | | 6 | |
| Permitted Phases | | | | 8 | | | 2 | | | 6 | | |
| Actuated Green, G (s) | | 67.0 | | | 67.0 | | | 21.0 | | | 21.0 | |
| Effective Green, g (s) | | 69.0 | | | 69.0 | | | 23.0 | | | 23.0 | |
| Actuated g/C Ratio | | 0.69 | | | 0.69 | | | 0.23 | | | 0.23 | |
| Clearance Time (s) | | 6.0 | | | 6.0 | | | 6.0 | | | 6.0 | |
| Lane Grp Cap (vph) | | 2416 | | | 2307 | | | 308 | | | 397 | |
| v/s Ratio Prot | | 0.14 | | | | | | | | | | |
| v/s Ratio Perm | | | | | c0.59 | | | c0.08 | | | 0.04 | |
| v/c Ratio | | 0.21 | | | 0.85 | | | 0.33 | | | 0.17 | |
| Uniform Delay, d ₁ | | 5.6 | | | 11.6 | | | 32.1 | | | 30.8 | |
| Progression Factor | | 0.45 | | | 1.00 | | | 1.00 | | | 1.00 | |
| Incremental Delay, d ₂ | | 0.2 | | | 4.1 | | | 2.9 | | | 0.9 | |
| Delay (s) | | 2.7 | | | 15.7 | | | 34.9 | | | 31.8 | |
| Level of Service | | A | | | B | | | C | | | C | |
| Approach Delay (s) | | 2.7 | | | 15.7 | | | 34.9 | | | 31.8 | |
| Approach LOS | | A | | | B | | | C | | | C | |

| Intersection Summary | | | |
|-----------------------------------|-------|----------------------|-----|
| HCM Average Control Delay | 14.5 | HCM Level of Service | B |
| HCM Volume to Capacity ratio | 0.72 | | |
| Actuated Cycle Length (s) | 100.0 | Sum of lost time (s) | 8.0 |
| Intersection Capacity Utilization | 76.8% | ICU Level of Service | D |
| Analysis Period (min) | 15 | | |

c Critical Lane Group

HCM Unsignalized Intersection Capacity Analysis
4: G STREET & 10th STREET

AM Peak - Background
7/17/2007

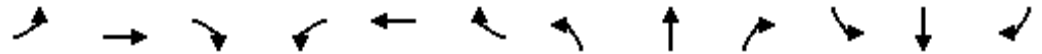

| Movement | EBL | EBT | EBR | WBL | WBT | WBR | NBL | NBT | NBR | SBL | SBT | SBR |
|-----------------------------------|-------------|-------------|-------------|----------------------|------|------|------|------|------|------|------|------|
| Lane Configurations | | | | | ↕ | | | ↕ | | | ↕ | |
| Sign Control | Stop | | | Stop | | | Stop | | | Stop | | |
| Volume (vph) | 0 | 0 | 0 | 5 | 235 | 19 | 33 | 55 | 0 | 0 | 73 | 24 |
| Peak Hour Factor | 0.92 | 0.92 | 0.92 | 0.63 | 0.92 | 0.68 | 0.83 | 0.63 | 0.92 | 0.92 | 0.79 | 0.75 |
| Hourly flow rate (vph) | 0 | 0 | 0 | 8 | 255 | 28 | 40 | 87 | 0 | 0 | 92 | 32 |
| Direction, Lane # | WB 1 | NB 1 | SB 1 | | | | | | | | | |
| Volume Total (vph) | 291 | 127 | 124 | | | | | | | | | |
| Volume Left (vph) | 8 | 40 | 0 | | | | | | | | | |
| Volume Right (vph) | 28 | 0 | 32 | | | | | | | | | |
| Hadj (s) | -0.02 | 0.10 | -0.12 | | | | | | | | | |
| Departure Headway (s) | 4.5 | 4.9 | 4.7 | | | | | | | | | |
| Degree Utilization, x | 0.36 | 0.17 | 0.16 | | | | | | | | | |
| Capacity (veh/h) | 761 | 694 | 718 | | | | | | | | | |
| Control Delay (s) | 10.1 | 8.9 | 8.5 | | | | | | | | | |
| Approach Delay (s) | 10.1 | 8.9 | 8.5 | | | | | | | | | |
| Approach LOS | B | A | A | | | | | | | | | |
| Intersection Summary | | | | | | | | | | | | |
| Delay | | | 9.4 | | | | | | | | | |
| HCM Level of Service | | | A | | | | | | | | | |
| Intersection Capacity Utilization | | | 31.8% | ICU Level of Service | | | | | | | | A |
| Analysis Period (min) | | | 15 | | | | | | | | | |

HCM Unsignalized Intersection Capacity Analysis
 5: G STREET & 8th STREET

AM Peak - Background
 7/17/2007



| Movement | EBL | EBT | EBR | WBL | WBT | WBR | NBL | NBT | NBR | SBL | SBT | SBR |
|-----------------------------------|-------|------|-------|----------------------|------|------|------|------|------|------|------|------|
| Lane Configurations | | | | | ↕ | | | ↕ | | | ↕ | |
| Sign Control | | Stop | | | Stop | | | Stop | | | Stop | |
| Volume (vph) | 0 | 0 | 0 | 11 | 277 | 57 | 47 | 244 | 0 | 0 | 180 | 19 |
| Peak Hour Factor | 0.92 | 0.92 | 0.92 | 0.39 | 0.95 | 0.89 | 0.78 | 0.91 | 0.92 | 0.92 | 0.87 | 0.68 |
| Hourly flow rate (vph) | 0 | 0 | 0 | 28 | 292 | 64 | 60 | 268 | 0 | 0 | 207 | 28 |
| Direction, Lane # | WB 1 | NB 1 | SB 1 | | | | | | | | | |
| Volume Total (vph) | 384 | 328 | 235 | | | | | | | | | |
| Volume Left (vph) | 28 | 60 | 0 | | | | | | | | | |
| Volume Right (vph) | 64 | 0 | 28 | | | | | | | | | |
| Hadj (s) | -0.05 | 0.07 | -0.04 | | | | | | | | | |
| Departure Headway (s) | 5.4 | 5.5 | 5.5 | | | | | | | | | |
| Degree Utilization, x | 0.57 | 0.50 | 0.36 | | | | | | | | | |
| Capacity (veh/h) | 635 | 620 | 609 | | | | | | | | | |
| Control Delay (s) | 15.3 | 13.8 | 11.6 | | | | | | | | | |
| Approach Delay (s) | 15.3 | 13.8 | 11.6 | | | | | | | | | |
| Approach LOS | C | B | B | | | | | | | | | |
| Intersection Summary | | | | | | | | | | | | |
| Delay | | | 13.9 | | | | | | | | | |
| HCM Level of Service | | | B | | | | | | | | | |
| Intersection Capacity Utilization | | | 54.7% | ICU Level of Service | | | | | | | | A |
| Analysis Period (min) | | | 15 | | | | | | | | | |

HCM Unsignalized Intersection Capacity Analysis
 6: Alley Access East & 10th STREET

AM Peak - Background
 7/17/2007



| Movement | EBL | EBR | NBL | NBT | SBT | SBR |
|-----------------------------------|-------------|-------------|----------------------|------|------|------|
| Lane Configurations | | | | | | |
| Sign Control | Stop | | | Free | Free | |
| Grade | 0% | | | 0% | 0% | |
| Volume (veh/h) | 2 | 6 | 6 | 69 | 83 | 5 |
| Peak Hour Factor | 0.92 | 0.92 | 0.92 | 0.92 | 0.92 | 0.92 |
| Hourly flow rate (vph) | 2 | 7 | 7 | 75 | 90 | 5 |
| Pedestrians | | | | | | |
| Lane Width (ft) | | | | | | |
| Walking Speed (ft/s) | | | | | | |
| Percent Blockage | | | | | | |
| Right turn flare (veh) | | | | | | |
| Median type | None | | | | | |
| Median storage (veh) | | | | | | |
| Upstream signal (ft) | 199 | | | | | |
| pX, platoon unblocked | | | | | | |
| vC, conflicting volume | 181 | 93 | 96 | | | |
| vC1, stage 1 conf vol | | | | | | |
| vC2, stage 2 conf vol | | | | | | |
| vCu, unblocked vol | 181 | 93 | 96 | | | |
| tC, single (s) | 6.4 | 6.2 | 4.1 | | | |
| tC, 2 stage (s) | | | | | | |
| tF (s) | 3.5 | 3.3 | 2.2 | | | |
| p0 queue free % | 100 | 99 | 100 | | | |
| cM capacity (veh/h) | 805 | 964 | 1498 | | | |
| Direction, Lane # | EB 1 | NB 1 | SB 1 | | | |
| Volume Total | 9 | 82 | 96 | | | |
| Volume Left | 2 | 7 | 0 | | | |
| Volume Right | 7 | 0 | 5 | | | |
| cSH | 919 | 1498 | 1700 | | | |
| Volume to Capacity | 0.01 | 0.00 | 0.06 | | | |
| Queue Length 95th (ft) | 1 | 0 | 0 | | | |
| Control Delay (s) | 9.0 | 0.6 | 0.0 | | | |
| Lane LOS | A | A | | | | |
| Approach Delay (s) | 9.0 | 0.6 | 0.0 | | | |
| Approach LOS | A | | | | | |
| Intersection Summary | | | | | | |
| Average Delay | | | 0.7 | | | |
| Intersection Capacity Utilization | 18.6% | | ICU Level of Service | A | | |
| Analysis Period (min) | 15 | | | | | |

HCM Unsignalized Intersection Capacity Analysis
 7: Alley Access West & 8th STREET

AM Peak - Background
 7/17/2007



| Movement | WBL | WBR | NBT | NBR | SBL | SBT |
|------------------------|------|------|------|------|------|------|
| Lane Configurations | ↔ | | ↑ | | | ↑ |
| Sign Control | Stop | | Free | | | Free |
| Grade | 0% | | 0% | | | 0% |
| Volume (veh/h) | 0 | 2 | 284 | 0 | 0 | 200 |
| Peak Hour Factor | 0.92 | 0.92 | 0.92 | 0.92 | 0.92 | 0.92 |
| Hourly flow rate (vph) | 0 | 2 | 309 | 0 | 0 | 217 |
| Pedestrians | | | | | | |
| Lane Width (ft) | | | | | | |
| Walking Speed (ft/s) | | | | | | |
| Percent Blockage | | | | | | |
| Right turn flare (veh) | | | | | | |
| Median type | None | | | | | |
| Median storage (veh) | | | | | | |
| Upstream signal (ft) | | | | | | 221 |
| pX, platoon unblocked | 0.90 | | | | | |
| vC, conflicting volume | 526 | 309 | | | 309 | |
| vC1, stage 1 conf vol | | | | | | |
| vC2, stage 2 conf vol | | | | | | |
| vCu, unblocked vol | 472 | 309 | | | 309 | |
| tC, single (s) | 6.4 | 6.2 | | | 4.1 | |
| tC, 2 stage (s) | | | | | | |
| tF (s) | 3.5 | 3.3 | | | 2.2 | |
| p0 queue free % | 100 | 100 | | | 100 | |
| cM capacity (veh/h) | 494 | 731 | | | 1252 | |

| Direction, Lane # | WB 1 | NB 1 | SB 1 |
|------------------------|------|------|------|
| Volume Total | 2 | 309 | 217 |
| Volume Left | 0 | 0 | 0 |
| Volume Right | 2 | 0 | 0 |
| cSH | 731 | 1700 | 1700 |
| Volume to Capacity | 0.00 | 0.18 | 0.13 |
| Queue Length 95th (ft) | 0 | 0 | 0 |
| Control Delay (s) | 9.9 | 0.0 | 0.0 |
| Lane LOS | A | | |
| Approach Delay (s) | 9.9 | 0.0 | 0.0 |
| Approach LOS | A | | |

| Intersection Summary | | | |
|-----------------------------------|--|-------|------------------------|
| Average Delay | | 0.0 | |
| Intersection Capacity Utilization | | 24.9% | ICU Level of Service A |
| Analysis Period (min) | | 15 | |

HCM Signalized Intersection Capacity Analysis
 1: H STREET & 8th STREET

PM Peak - Background
 7/17/2007



| Movement | EBL | EBT | EBR | WBL | WBT | WBR | NBL | NBT | NBR | SBL | SBT | SBR |
|-----------------------------------|------|-------|------|------|------|------|------|------|------|------|-------|------|
| Lane Configurations | | ↕↕ | | | ↕↕ | | | ↕ | | | ↕↕ | |
| Ideal Flow (vphpl) | 1900 | 1900 | 1900 | 1900 | 1900 | 1900 | 1900 | 1900 | 1900 | 1900 | 1900 | 1900 |
| Total Lost time (s) | | 4.0 | | | 4.0 | | | 4.0 | | | 4.0 | |
| Lane Util. Factor | | 0.95 | | | 0.95 | | | 1.00 | | | 1.00 | |
| Fr _t | | 0.99 | | | 0.98 | | | 0.99 | | | 0.98 | |
| Fl _t Protected | | 1.00 | | | 1.00 | | | 1.00 | | | 0.99 | |
| Satd. Flow (prot) | | 3512 | | | 3485 | | | 1850 | | | 1807 | |
| Fl _t Permitted | | 0.89 | | | 1.00 | | | 1.00 | | | 0.69 | |
| Satd. Flow (perm) | | 3116 | | | 3485 | | | 1850 | | | 1251 | |
| Volume (vph) | 45 | 1269 | 29 | 0 | 529 | 52 | 0 | 243 | 11 | 46 | 176 | 44 |
| Peak-hour factor, PHF | 0.75 | 0.98 | 0.56 | 0.50 | 0.88 | 0.76 | 0.42 | 0.83 | 0.69 | 0.82 | 0.77 | 0.79 |
| Adj. Flow (vph) | 60 | 1295 | 52 | 0 | 601 | 68 | 0 | 293 | 16 | 56 | 229 | 56 |
| RTOR Reduction (vph) | 0 | 3 | 0 | 0 | 9 | 0 | 0 | 2 | 0 | 0 | 7 | 0 |
| Lane Group Flow (vph) | 0 | 1404 | 0 | 0 | 660 | 0 | 0 | 307 | 0 | 0 | 334 | 0 |
| Turn Type | Perm | | | | | | Perm | | | | | |
| Protected Phases | | 4 | | | 8 | | | 2 | | | 6 | |
| Permitted Phases | 4 | | | | | | | | | 6 | | |
| Actuated Green, G (s) | | 63.0 | | | 63.0 | | | 26.0 | | | 26.0 | |
| Effective Green, g (s) | | 64.0 | | | 64.0 | | | 28.0 | | | 28.0 | |
| Actuated g/C Ratio | | 0.64 | | | 0.64 | | | 0.28 | | | 0.28 | |
| Clearance Time (s) | | 5.0 | | | 5.0 | | | 6.0 | | | 6.0 | |
| Lane Grp Cap (vph) | | 1994 | | | 2230 | | | 518 | | | 350 | |
| v/s Ratio Prot | | | | | 0.19 | | | 0.17 | | | | |
| v/s Ratio Perm | | c0.45 | | | | | | | | | c0.27 | |
| v/c Ratio | | 0.70 | | | 0.30 | | | 0.59 | | | 0.95 | |
| Uniform Delay, d ₁ | | 11.8 | | | 8.0 | | | 31.1 | | | 35.4 | |
| Progression Factor | | 1.00 | | | 0.42 | | | 1.00 | | | 1.00 | |
| Incremental Delay, d ₂ | | 2.1 | | | 0.3 | | | 4.9 | | | 37.7 | |
| Delay (s) | | 13.9 | | | 3.7 | | | 36.0 | | | 73.1 | |
| Level of Service | | B | | | A | | | D | | | E | |
| Approach Delay (s) | | 13.9 | | | 3.7 | | | 36.0 | | | 73.1 | |
| Approach LOS | | B | | | A | | | D | | | E | |

| Intersection Summary | | | |
|-----------------------------------|-------|----------------------|-----|
| HCM Average Control Delay | 21.3 | HCM Level of Service | C |
| HCM Volume to Capacity ratio | 0.78 | | |
| Actuated Cycle Length (s) | 100.0 | Sum of lost time (s) | 8.0 |
| Intersection Capacity Utilization | 94.9% | ICU Level of Service | F |
| Analysis Period (min) | 15 | | |

c Critical Lane Group

HCM Signalized Intersection Capacity Analysis
 2: H STREET & 9th STREET

PM Peak - Background
 7/17/2007



| Movement | EBL | EBT | EBR | WBL | WBT | WBR | NBL | NBT | NBR | SBL | SBT | SBR |
|------------------------|------|-------|------|------|------|------|------|-------|------|------|------|------|
| Lane Configurations | | ↕↕ | | | ↕↕ | | | ↕ | | | ↕ | |
| Ideal Flow (vphpl) | 1900 | 1900 | 1900 | 1900 | 1900 | 1900 | 1900 | 1900 | 1900 | 1900 | 1900 | 1900 |
| Total Lost time (s) | | 4.0 | | | 4.0 | | | 4.0 | | | 4.0 | |
| Lane Util. Factor | | 0.95 | | | 0.95 | | | 1.00 | | | 1.00 | |
| Frt | | 1.00 | | | 0.99 | | | 0.94 | | | 0.95 | |
| Flt Protected | | 1.00 | | | 1.00 | | | 0.98 | | | 0.98 | |
| Satd. Flow (prot) | | 3523 | | | 3483 | | | 1726 | | | 1736 | |
| Flt Permitted | | 0.93 | | | 0.87 | | | 0.88 | | | 0.86 | |
| Satd. Flow (perm) | | 3273 | | | 3032 | | | 1553 | | | 1526 | |
| Volume (vph) | 15 | 1358 | 24 | 15 | 625 | 51 | 20 | 14 | 29 | 32 | 15 | 18 |
| Peak-hour factor, PHF | 0.54 | 0.93 | 0.67 | 0.63 | 0.90 | 0.67 | 0.56 | 0.58 | 0.66 | 0.89 | 0.75 | 0.56 |
| Adj. Flow (vph) | 28 | 1460 | 36 | 24 | 694 | 76 | 36 | 24 | 44 | 36 | 20 | 32 |
| RTOR Reduction (vph) | 0 | 2 | 0 | 0 | 8 | 0 | 0 | 26 | 0 | 0 | 20 | 0 |
| Lane Group Flow (vph) | 0 | 1522 | 0 | 0 | 786 | 0 | 0 | 78 | 0 | 0 | 68 | 0 |
| Turn Type | Perm | | Perm | | Perm | | Perm | | Perm | | Perm | |
| Protected Phases | | 4 | | | 8 | | | 2 | | | 6 | |
| Permitted Phases | 4 | | | 8 | | | 2 | | | 6 | | |
| Actuated Green, G (s) | | 66.0 | | | 66.0 | | | 23.0 | | | 23.0 | |
| Effective Green, g (s) | | 67.0 | | | 67.0 | | | 25.0 | | | 25.0 | |
| Actuated g/C Ratio | | 0.67 | | | 0.67 | | | 0.25 | | | 0.25 | |
| Clearance Time (s) | | 5.0 | | | 5.0 | | | 6.0 | | | 6.0 | |
| Lane Grp Cap (vph) | | 2193 | | | 2031 | | | 388 | | | 382 | |
| v/s Ratio Prot | | | | | | | | | | | | |
| v/s Ratio Perm | | c0.47 | | | 0.26 | | | c0.05 | | | 0.04 | |
| v/c Ratio | | 0.69 | | | 0.39 | | | 0.20 | | | 0.18 | |
| Uniform Delay, d1 | | 10.2 | | | 7.4 | | | 29.6 | | | 29.4 | |
| Progression Factor | | 0.32 | | | 0.61 | | | 1.00 | | | 1.00 | |
| Incremental Delay, d2 | | 1.4 | | | 0.5 | | | 1.2 | | | 1.0 | |
| Delay (s) | | 4.7 | | | 5.0 | | | 30.8 | | | 30.4 | |
| Level of Service | | A | | | A | | | C | | | C | |
| Approach Delay (s) | | 4.7 | | | 5.0 | | | 30.8 | | | 30.4 | |
| Approach LOS | | A | | | A | | | C | | | C | |

Intersection Summary

| | | | |
|-----------------------------------|-------|----------------------|-----|
| HCM Average Control Delay | 6.8 | HCM Level of Service | A |
| HCM Volume to Capacity ratio | 0.56 | | |
| Actuated Cycle Length (s) | 100.0 | Sum of lost time (s) | 8.0 |
| Intersection Capacity Utilization | 61.4% | ICU Level of Service | B |
| Analysis Period (min) | 15 | | |

c Critical Lane Group

HCM Signalized Intersection Capacity Analysis
 3: H STREET & 10th STREET

PM Peak - Background
 7/17/2007

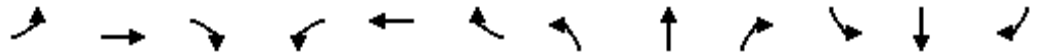

| Movement | EBL | EBT | EBR | WBL | WBT | WBR | NBL | NBT | NBR | SBL | SBT | SBR |
|------------------------|------|-------|------|------|------|------|------|-------|------|------|------|------|
| Lane Configurations | | ↑↑ | | | ↑↑ | | | ↑↓ | | | ↑↓ | |
| Ideal Flow (vphpl) | 1900 | 1900 | 1900 | 1900 | 1900 | 1900 | 1900 | 1900 | 1900 | 1900 | 1900 | 1900 |
| Total Lost time (s) | | 4.0 | | | 4.0 | | | 4.0 | | | 4.0 | |
| Lane Util. Factor | | 0.95 | | | 0.95 | | | 1.00 | | | 1.00 | |
| Frt | | 0.99 | | | 1.00 | | | 0.94 | | | 0.97 | |
| Flt Protected | | 1.00 | | | 1.00 | | | 0.97 | | | 0.99 | |
| Satd. Flow (prot) | | 3520 | | | 3531 | | | 1699 | | | 1785 | |
| Flt Permitted | | 1.00 | | | 0.83 | | | 0.70 | | | 0.88 | |
| Satd. Flow (perm) | | 3520 | | | 2935 | | | 1228 | | | 1589 | |
| Volume (vph) | 0 | 1340 | 43 | 19 | 598 | 0 | 69 | 0 | 48 | 34 | 62 | 21 |
| Peak-hour factor, PHF | 0.25 | 0.96 | 0.83 | 0.59 | 0.92 | 0.25 | 0.82 | 0.25 | 0.63 | 0.77 | 0.78 | 0.66 |
| Adj. Flow (vph) | 0 | 1396 | 52 | 32 | 650 | 0 | 84 | 0 | 76 | 44 | 79 | 32 |
| RTOR Reduction (vph) | 0 | 3 | 0 | 0 | 0 | 0 | 0 | 33 | 0 | 0 | 9 | 0 |
| Lane Group Flow (vph) | 0 | 1445 | 0 | 0 | 682 | 0 | 0 | 127 | 0 | 0 | 146 | 0 |
| Turn Type | | | | Perm | | Perm | | | Perm | | | |
| Protected Phases | | 4 | | | 8 | | | 2 | | | 6 | |
| Permitted Phases | | | | 8 | | | 2 | | | 6 | | |
| Actuated Green, G (s) | | 69.0 | | | 69.0 | | | 20.0 | | | 20.0 | |
| Effective Green, g (s) | | 70.0 | | | 70.0 | | | 22.0 | | | 22.0 | |
| Actuated g/C Ratio | | 0.70 | | | 0.70 | | | 0.22 | | | 0.22 | |
| Clearance Time (s) | | 5.0 | | | 5.0 | | | 6.0 | | | 6.0 | |
| Lane Grp Cap (vph) | | 2464 | | | 2055 | | | 270 | | | 350 | |
| v/s Ratio Prot | | c0.41 | | | | | | | | | | |
| v/s Ratio Perm | | | | | 0.23 | | | c0.10 | | | 0.09 | |
| v/c Ratio | | 0.59 | | | 0.33 | | | 0.47 | | | 0.42 | |
| Uniform Delay, d1 | | 7.6 | | | 5.9 | | | 33.9 | | | 33.5 | |
| Progression Factor | | 0.32 | | | 1.00 | | | 1.00 | | | 1.00 | |
| Incremental Delay, d2 | | 0.8 | | | 0.4 | | | 5.8 | | | 3.6 | |
| Delay (s) | | 3.2 | | | 6.3 | | | 39.7 | | | 37.1 | |
| Level of Service | | A | | | A | | | D | | | D | |
| Approach Delay (s) | | 3.2 | | | 6.3 | | | 39.7 | | | 37.1 | |
| Approach LOS | | A | | | A | | | D | | | D | |

| Intersection Summary | | | |
|-----------------------------------|-------|----------------------|-----|
| HCM Average Control Delay | 8.6 | HCM Level of Service | A |
| HCM Volume to Capacity ratio | 0.56 | | |
| Actuated Cycle Length (s) | 100.0 | Sum of lost time (s) | 8.0 |
| Intersection Capacity Utilization | 57.9% | ICU Level of Service | B |
| Analysis Period (min) | 15 | | |

c Critical Lane Group

HCM Unsignalized Intersection Capacity Analysis
 4: G STREET & 10th STREET

PM Peak - Background
 7/17/2007

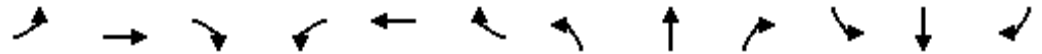

| Movement | EBL | EBT | EBR | WBL | WBT | WBR | NBL | NBT | NBR | SBL | SBT | SBR |
|------------------------|------|------|------|------|------|------|------|------|------|------|------|------|
| Lane Configurations | | | | | ↕ | | | ↕ | | | ↕ | |
| Sign Control | Stop | | | Stop | | | Stop | | | Stop | | |
| Volume (vph) | 0 | 0 | 0 | 6 | 75 | 18 | 17 | 84 | 0 | 0 | 94 | 18 |
| Peak Hour Factor | 0.25 | 0.25 | 0.25 | 0.38 | 0.78 | 0.75 | 0.71 | 0.81 | 0.25 | 0.25 | 0.90 | 0.90 |
| Hourly flow rate (vph) | 0 | 0 | 0 | 16 | 96 | 24 | 24 | 104 | 0 | 0 | 104 | 20 |

| Direction, Lane # | WB 1 | NB 1 | SB 1 |
|-----------------------|-------|------|-------|
| Volume Total (vph) | 136 | 128 | 124 |
| Volume Left (vph) | 16 | 24 | 0 |
| Volume Right (vph) | 24 | 0 | 20 |
| Hadj (s) | -0.05 | 0.07 | -0.06 |
| Departure Headway (s) | 4.4 | 4.4 | 4.3 |
| Degree Utilization, x | 0.17 | 0.16 | 0.15 |
| Capacity (veh/h) | 763 | 780 | 797 |
| Control Delay (s) | 8.3 | 8.3 | 8.1 |
| Approach Delay (s) | 8.3 | 8.3 | 8.1 |
| Approach LOS | A | A | A |

| Intersection Summary | | |
|-----------------------------------|-------|------------------------|
| Delay | | 8.2 |
| HCM Level of Service | | A |
| Intersection Capacity Utilization | 24.1% | ICU Level of Service A |
| Analysis Period (min) | | 15 |

HCM Unsignalized Intersection Capacity Analysis
 5: G STREET & 8th STREET

PM Peak - Background
 7/17/2007

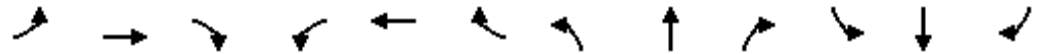

| Movement | EBL | EBT | EBR | WBL | WBT | WBR | NBL | NBT | NBR | SBL | SBT | SBR |
|------------------------|------|------|------|------|------|------|------|------|------|------|------|------|
| Lane Configurations | | | | | ↕ | | | ↕ | | | ↕ | |
| Sign Control | Stop | | | Stop | | | Stop | | | Stop | | |
| Volume (vph) | 0 | 0 | 0 | 7 | 86 | 48 | 27 | 223 | 0 | 0 | 195 | 8 |
| Peak Hour Factor | 0.25 | 0.25 | 0.25 | 0.58 | 0.74 | 0.71 | 0.75 | 0.94 | 0.25 | 0.25 | 0.90 | 0.40 |
| Hourly flow rate (vph) | 0 | 0 | 0 | 12 | 116 | 68 | 36 | 237 | 0 | 0 | 217 | 20 |

| Direction, Lane # | WB 1 | NB 1 | SB 1 |
|-----------------------|-------|------|-------|
| Volume Total (vph) | 196 | 273 | 237 |
| Volume Left (vph) | 12 | 36 | 0 |
| Volume Right (vph) | 68 | 0 | 20 |
| Hadj (s) | -0.16 | 0.06 | -0.02 |
| Departure Headway (s) | 5.0 | 4.8 | 4.7 |
| Degree Utilization, x | 0.27 | 0.36 | 0.31 |
| Capacity (veh/h) | 669 | 722 | 720 |
| Control Delay (s) | 9.8 | 10.5 | 9.9 |
| Approach Delay (s) | 9.8 | 10.5 | 9.9 |
| Approach LOS | A | B | A |

| Intersection Summary | | |
|-----------------------------------|-------|------------------------|
| Delay | | 10.1 |
| HCM Level of Service | | B |
| Intersection Capacity Utilization | 41.8% | ICU Level of Service A |
| Analysis Period (min) | | 15 |



| Movement | EBL | EBR | NBL | NBT | SBT | SBR |
|-----------------------------------|-------------|-------------|----------------------|------|------|------|
| Lane Configurations | | | | | | |
| Sign Control | Stop | | | Free | Free | |
| Grade | 0% | | | 0% | 0% | |
| Volume (veh/h) | 2 | 6 | 6 | 69 | 83 | 5 |
| Peak Hour Factor | 0.92 | 0.92 | 0.92 | 0.92 | 0.92 | 0.92 |
| Hourly flow rate (vph) | 2 | 7 | 7 | 75 | 90 | 5 |
| Pedestrians | | | | | | |
| Lane Width (ft) | | | | | | |
| Walking Speed (ft/s) | | | | | | |
| Percent Blockage | | | | | | |
| Right turn flare (veh) | | | | | | |
| Median type | None | | | | | |
| Median storage (veh) | | | | | | |
| Upstream signal (ft) | 199 | | | | | |
| pX, platoon unblocked | | | | | | |
| vC, conflicting volume | 181 | 93 | 96 | | | |
| vC1, stage 1 conf vol | | | | | | |
| vC2, stage 2 conf vol | | | | | | |
| vCu, unblocked vol | 181 | 93 | 96 | | | |
| tC, single (s) | 6.4 | 6.2 | 4.1 | | | |
| tC, 2 stage (s) | | | | | | |
| tF (s) | 3.5 | 3.3 | 2.2 | | | |
| p0 queue free % | 100 | 99 | 100 | | | |
| cM capacity (veh/h) | 805 | 964 | 1498 | | | |
| Direction, Lane # | EB 1 | NB 1 | SB 1 | | | |
| Volume Total | 9 | 82 | 96 | | | |
| Volume Left | 2 | 7 | 0 | | | |
| Volume Right | 7 | 0 | 5 | | | |
| cSH | 919 | 1498 | 1700 | | | |
| Volume to Capacity | 0.01 | 0.00 | 0.06 | | | |
| Queue Length 95th (ft) | 1 | 0 | 0 | | | |
| Control Delay (s) | 9.0 | 0.6 | 0.0 | | | |
| Lane LOS | A | A | | | | |
| Approach Delay (s) | 9.0 | 0.6 | 0.0 | | | |
| Approach LOS | A | | | | | |
| Intersection Summary | | | | | | |
| Average Delay | | | 0.7 | | | |
| Intersection Capacity Utilization | 18.6% | | ICU Level of Service | A | | |
| Analysis Period (min) | 15 | | | | | |



| Movement | WBL | WBR | NBT | NBR | SBL | SBT |
|-----------------------------------|------|-------|------|----------------------|------|------|
| Lane Configurations | ↔ | | ↑ | | | ↑ |
| Sign Control | Stop | | Free | | | Free |
| Grade | 0% | | 0% | | | 0% |
| Volume (veh/h) | 0 | 4 | 272 | 0 | 0 | 212 |
| Peak Hour Factor | 0.92 | 0.92 | 0.92 | 0.92 | 0.92 | 0.92 |
| Hourly flow rate (vph) | 0 | 4 | 296 | 0 | 0 | 230 |
| Pedestrians | | | | | | |
| Lane Width (ft) | | | | | | |
| Walking Speed (ft/s) | | | | | | |
| Percent Blockage | | | | | | |
| Right turn flare (veh) | | | | | | |
| Median type | None | | | | | |
| Median storage (veh) | | | | | | |
| Upstream signal (ft) | 221 | | | | | |
| pX, platoon unblocked | | | | | | |
| vC, conflicting volume | 526 | 296 | | | 296 | |
| vC1, stage 1 conf vol | | | | | | |
| vC2, stage 2 conf vol | | | | | | |
| vCu, unblocked vol | 526 | 296 | | | 296 | |
| tC, single (s) | 6.4 | 6.2 | | | 4.1 | |
| tC, 2 stage (s) | | | | | | |
| tF (s) | 3.5 | 3.3 | | | 2.2 | |
| p0 queue free % | 100 | 99 | | | 100 | |
| cM capacity (veh/h) | 512 | 744 | | | 1266 | |
| Direction, Lane # | WB 1 | NB 1 | SB 1 | | | |
| Volume Total | 4 | 296 | 230 | | | |
| Volume Left | 0 | 0 | 0 | | | |
| Volume Right | 4 | 0 | 0 | | | |
| cSH | 744 | 1700 | 1700 | | | |
| Volume to Capacity | 0.01 | 0.17 | 0.14 | | | |
| Queue Length 95th (ft) | 0 | 0 | 0 | | | |
| Control Delay (s) | 9.9 | 0.0 | 0.0 | | | |
| Lane LOS | A | | | | | |
| Approach Delay (s) | 9.9 | 0.0 | 0.0 | | | |
| Approach LOS | A | | | | | |
| Intersection Summary | | | | | | |
| Average Delay | | | 0.1 | | | |
| Intersection Capacity Utilization | | 24.3% | | ICU Level of Service | | A |
| Analysis Period (min) | | | 15 | | | |

HCM Signalized Intersection Capacity Analysis
 1: H STREET & 8th STREET

AM Peak - Total Future
 7/17/2007



| Movement | EBL | EBT | EBR | WBL | WBT | WBR | NBL | NBT | NBR | SBL | SBT | SBR |
|-----------------------------------|------|------|------|------|-------|------|------|------|------|------|-------|------|
| Lane Configurations | | ↕↕ | | | ↕↕ | | | ↕ | | | ↕↕ | |
| Ideal Flow (vphpl) | 1900 | 1900 | 1900 | 1900 | 1900 | 1900 | 1900 | 1900 | 1900 | 1900 | 1900 | 1900 |
| Total Lost time (s) | | 4.0 | | | 4.0 | | | 4.0 | | | 4.0 | |
| Lane Util. Factor | | 0.95 | | | 0.95 | | | 1.00 | | | 1.00 | |
| Fr _t | | 0.97 | | | 1.00 | | | 0.98 | | | 0.98 | |
| Fl _t Protected | | 1.00 | | | 1.00 | | | 1.00 | | | 1.00 | |
| Satd. Flow (prot) | | 3439 | | | 3531 | | | 1823 | | | 1827 | |
| Fl _t Permitted | | 0.70 | | | 1.00 | | | 1.00 | | | 0.79 | |
| Satd. Flow (perm) | | 2415 | | | 3531 | | | 1823 | | | 1455 | |
| Volume (vph) | 23 | 417 | 57 | 0 | 1767 | 29 | 0 | 207 | 26 | 14 | 192 | 25 |
| Peak-hour factor, PHF | 0.58 | 0.86 | 0.54 | 0.25 | 0.94 | 1.00 | 0.50 | 0.82 | 0.54 | 0.67 | 0.86 | 0.78 |
| Adj. Flow (vph) | 40 | 485 | 106 | 0 | 1880 | 29 | 0 | 252 | 48 | 21 | 223 | 32 |
| RTOR Reduction (vph) | 0 | 17 | 0 | 0 | 1 | 0 | 0 | 7 | 0 | 0 | 5 | 0 |
| Lane Group Flow (vph) | 0 | 614 | 0 | 0 | 1908 | 0 | 0 | 293 | 0 | 0 | 271 | 0 |
| Turn Type | Perm | | | | | | Perm | | | | | |
| Protected Phases | | 4 | | | 8 | | | 2 | | | 6 | |
| Permitted Phases | 4 | | | | | | | | | 6 | | |
| Actuated Green, G (s) | | 67.0 | | | 67.0 | | | 21.0 | | | 21.0 | |
| Effective Green, g (s) | | 69.0 | | | 69.0 | | | 23.0 | | | 23.0 | |
| Actuated g/C Ratio | | 0.69 | | | 0.69 | | | 0.23 | | | 0.23 | |
| Clearance Time (s) | | 6.0 | | | 6.0 | | | 6.0 | | | 6.0 | |
| Lane Grp Cap (vph) | | 1666 | | | 2436 | | | 419 | | | 335 | |
| v/s Ratio Prot | | | | | c0.54 | | | 0.16 | | | | |
| v/s Ratio Perm | | 0.25 | | | | | | | | | c0.19 | |
| v/c Ratio | | 0.37 | | | 0.78 | | | 0.70 | | | 0.81 | |
| Uniform Delay, d ₁ | | 6.4 | | | 10.5 | | | 35.3 | | | 36.4 | |
| Progression Factor | | 1.00 | | | 0.26 | | | 1.00 | | | 1.00 | |
| Incremental Delay, d ₂ | | 0.6 | | | 1.4 | | | 9.4 | | | 18.8 | |
| Delay (s) | | 7.1 | | | 4.1 | | | 44.7 | | | 55.2 | |
| Level of Service | | A | | | A | | | D | | | E | |
| Approach Delay (s) | | 7.1 | | | 4.1 | | | 44.7 | | | 55.2 | |
| Approach LOS | | A | | | A | | | D | | | E | |

Intersection Summary

| | | | |
|-----------------------------------|-------|----------------------|-----|
| HCM Average Control Delay | 13.2 | HCM Level of Service | B |
| HCM Volume to Capacity ratio | 0.79 | | |
| Actuated Cycle Length (s) | 100.0 | Sum of lost time (s) | 8.0 |
| Intersection Capacity Utilization | 79.7% | ICU Level of Service | D |
| Analysis Period (min) | 15 | | |

c Critical Lane Group

HCM Signalized Intersection Capacity Analysis
 2: H STREET & 9th STREET

AM Peak - Total Future
 7/17/2007

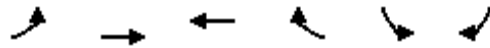

| Movement | EBL | EBT | WBT | WBR | SBL | SBR |
|------------------------|------|------|-------|------|-------|------|
| Lane Configurations | | ↕↕ | ↕↕ | | ↕↕ | |
| Ideal Flow (vphpl) | 1900 | 1900 | 1900 | 1900 | 1900 | 1900 |
| Total Lost time (s) | | 4.0 | 4.0 | | 4.0 | |
| Lane Util. Factor | | 0.95 | 0.95 | | 1.00 | |
| Frt | | 1.00 | 0.99 | | 0.95 | |
| Flt Protected | | 1.00 | 1.00 | | 0.97 | |
| Satd. Flow (prot) | | 3534 | 3513 | | 1715 | |
| Flt Permitted | | 0.85 | 1.00 | | 0.97 | |
| Satd. Flow (perm) | | 2993 | 3513 | | 1715 | |
| Volume (vph) | 7 | 452 | 1786 | 83 | 16 | 9 |
| Peak-hour factor, PHF | 0.44 | 0.93 | 0.89 | 0.80 | 0.81 | 0.75 |
| Adj. Flow (vph) | 16 | 486 | 2007 | 104 | 20 | 12 |
| RTOR Reduction (vph) | 0 | 0 | 4 | 0 | 10 | 0 |
| Lane Group Flow (vph) | 0 | 502 | 2107 | 0 | 22 | 0 |
| Turn Type | Perm | | | | | |
| Protected Phases | | 4 | 8 | | | |
| Permitted Phases | 4 | | | | 6 | |
| Actuated Green, G (s) | | 71.0 | 71.0 | | 18.0 | |
| Effective Green, g (s) | | 73.0 | 73.0 | | 19.0 | |
| Actuated g/C Ratio | | 0.73 | 0.73 | | 0.19 | |
| Clearance Time (s) | | 6.0 | 6.0 | | 5.0 | |
| Lane Grp Cap (vph) | | 2185 | 2564 | | 326 | |
| v/s Ratio Prot | | | c0.60 | | | |
| v/s Ratio Perm | | 0.17 | | | c0.01 | |
| v/c Ratio | | 0.23 | 0.82 | | 0.07 | |
| Uniform Delay, d1 | | 4.4 | 9.1 | | 33.2 | |
| Progression Factor | | 0.64 | 0.30 | | 1.00 | |
| Incremental Delay, d2 | | 0.2 | 1.7 | | 0.4 | |
| Delay (s) | | 3.0 | 4.4 | | 33.6 | |
| Level of Service | | A | A | | C | |
| Approach Delay (s) | | 3.0 | 4.4 | | 33.6 | |
| Approach LOS | | A | A | | C | |

Intersection Summary

| | | | |
|-----------------------------------|-------|----------------------|-----|
| HCM Average Control Delay | 4.5 | HCM Level of Service | A |
| HCM Volume to Capacity ratio | 0.67 | | |
| Actuated Cycle Length (s) | 100.0 | Sum of lost time (s) | 8.0 |
| Intersection Capacity Utilization | 62.0% | ICU Level of Service | B |
| Analysis Period (min) | 15 | | |

c Critical Lane Group

HCM Signalized Intersection Capacity Analysis
 3: H STREET & 10th STREET

AM Peak - Total Future
 7/17/2007

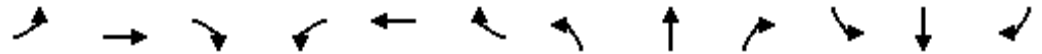

| Movement | EBL | EBT | EBR | WBL | WBT | WBR | NBL | NBT | NBR | SBL | SBT | SBR |
|-----------------------------------|------|------|------|------|-------|------|------|-------|------|------|------|------|
| Lane Configurations | | ↑↑ | | | ↑↑ | | | ↑↓ | | | ↑↓ | |
| Ideal Flow (vphpl) | 1900 | 1900 | 1900 | 1900 | 1900 | 1900 | 1900 | 1900 | 1900 | 1900 | 1900 | 1900 |
| Total Lost time (s) | | 4.0 | | | 4.0 | | | 4.0 | | | 4.0 | |
| Lane Util. Factor | | 0.95 | | | 0.95 | | | 1.00 | | | 1.00 | |
| Fr _t | | 0.99 | | | 1.00 | | | 0.97 | | | 0.98 | |
| Fl _t Protected | | 1.00 | | | 1.00 | | | 0.96 | | | 0.99 | |
| Satd. Flow (prot) | | 3487 | | | 3534 | | | 1744 | | | 1813 | |
| Fl _t Permitted | | 1.00 | | | 0.91 | | | 0.71 | | | 0.95 | |
| Satd. Flow (perm) | | 3487 | | | 3236 | | | 1297 | | | 1743 | |
| Volume (vph) | 0 | 438 | 33 | 35 | 1793 | 0 | 68 | 0 | 16 | 7 | 51 | 7 |
| Peak-hour factor, PHF | 0.92 | 0.92 | 0.64 | 0.58 | 0.93 | 0.92 | 0.65 | 0.92 | 0.63 | 0.58 | 0.88 | 0.56 |
| Adj. Flow (vph) | 0 | 476 | 52 | 60 | 1928 | 0 | 105 | 0 | 25 | 12 | 58 | 12 |
| RTOR Reduction (vph) | 0 | 8 | 0 | 0 | 0 | 0 | 0 | 8 | 0 | 0 | 6 | 0 |
| Lane Group Flow (vph) | 0 | 520 | 0 | 0 | 1988 | 0 | 0 | 122 | 0 | 0 | 76 | 0 |
| Turn Type | | | | Perm | | Perm | | | Perm | | | |
| Protected Phases | | 4 | | | 8 | | | 2 | | | 6 | |
| Permitted Phases | | | | 8 | | | 2 | | | 6 | | |
| Actuated Green, G (s) | | 67.0 | | | 67.0 | | | 21.0 | | | 21.0 | |
| Effective Green, g (s) | | 69.0 | | | 69.0 | | | 23.0 | | | 23.0 | |
| Actuated g/C Ratio | | 0.69 | | | 0.69 | | | 0.23 | | | 0.23 | |
| Clearance Time (s) | | 6.0 | | | 6.0 | | | 6.0 | | | 6.0 | |
| Lane Grp Cap (vph) | | 2406 | | | 2233 | | | 298 | | | 401 | |
| v/s Ratio Prot | | 0.15 | | | | | | | | | | |
| v/s Ratio Perm | | | | | c0.61 | | | c0.09 | | | 0.04 | |
| v/c Ratio | | 0.22 | | | 0.89 | | | 0.41 | | | 0.19 | |
| Uniform Delay, d ₁ | | 5.6 | | | 12.5 | | | 32.7 | | | 31.0 | |
| Progression Factor | | 0.38 | | | 1.00 | | | 1.00 | | | 1.00 | |
| Incremental Delay, d ₂ | | 0.2 | | | 5.8 | | | 4.1 | | | 1.0 | |
| Delay (s) | | 2.4 | | | 18.3 | | | 36.8 | | | 32.0 | |
| Level of Service | | A | | | B | | | D | | | C | |
| Approach Delay (s) | | 2.4 | | | 18.3 | | | 36.8 | | | 32.0 | |
| Approach LOS | | A | | | B | | | D | | | C | |

| Intersection Summary | | | |
|-----------------------------------|-------|----------------------|-----|
| HCM Average Control Delay | 16.5 | HCM Level of Service | B |
| HCM Volume to Capacity ratio | 0.77 | | |
| Actuated Cycle Length (s) | 100.0 | Sum of lost time (s) | 8.0 |
| Intersection Capacity Utilization | 85.1% | ICU Level of Service | E |
| Analysis Period (min) | 15 | | |

c Critical Lane Group

HCM Unsignalized Intersection Capacity Analysis
 4: G STREET & 10th STREET

AM Peak - Total Future
 7/17/2007

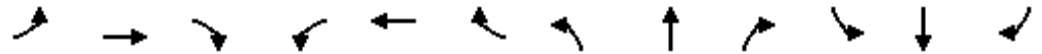

| Movement | EBL | EBT | EBR | WBL | WBT | WBR | NBL | NBT | NBR | SBL | SBT | SBR |
|-----------------------------------|-------|------|-------|----------------------|------|------|------|------|------|------|------|------|
| Lane Configurations | | | | | ↕ | | | ↕ | | | ↕ | |
| Sign Control | Stop | | | Stop | | | Stop | | | Stop | | |
| Volume (vph) | 0 | 0 | 0 | 5 | 234 | 25 | 33 | 67 | 0 | 0 | 76 | 26 |
| Peak Hour Factor | 0.90 | 0.90 | 0.90 | 0.63 | 0.92 | 0.68 | 0.83 | 0.63 | 0.92 | 0.92 | 0.79 | 0.75 |
| Hourly flow rate (vph) | 0 | 0 | 0 | 8 | 254 | 37 | 40 | 106 | 0 | 0 | 96 | 35 |
| Direction, Lane # | WB 1 | NB 1 | SB 1 | | | | | | | | | |
| Volume Total (vph) | 299 | 146 | 131 | | | | | | | | | |
| Volume Left (vph) | 8 | 40 | 0 | | | | | | | | | |
| Volume Right (vph) | 37 | 0 | 35 | | | | | | | | | |
| Hadj (s) | -0.03 | 0.09 | -0.12 | | | | | | | | | |
| Departure Headway (s) | 4.5 | 4.9 | 4.7 | | | | | | | | | |
| Degree Utilization, x | 0.38 | 0.20 | 0.17 | | | | | | | | | |
| Capacity (veh/h) | 751 | 690 | 710 | | | | | | | | | |
| Control Delay (s) | 10.3 | 9.1 | 8.7 | | | | | | | | | |
| Approach Delay (s) | 10.3 | 9.1 | 8.7 | | | | | | | | | |
| Approach LOS | B | A | A | | | | | | | | | |
| Intersection Summary | | | | | | | | | | | | |
| Delay | | | 9.6 | | | | | | | | | |
| HCM Level of Service | | | A | | | | | | | | | |
| Intersection Capacity Utilization | | | 32.8% | ICU Level of Service | | | | | | | | A |
| Analysis Period (min) | | | 15 | | | | | | | | | |

HCM Unsignalized Intersection Capacity Analysis
 5: G STREET & 8th STREET

AM Peak - Total Future
 7/17/2007



| Movement | EBL | EBT | EBR | WBL | WBT | WBR | NBL | NBT | NBR | SBL | SBT | SBR |
|-----------------------------------|-------------|-------------|-------------|----------------------|------|------|------|------|------|------|------|------|
| Lane Configurations | | | | | ↔ | | | ↔ | | | ↔ | |
| Sign Control | Stop | | | Stop | | | Stop | | | Stop | | |
| Volume (vph) | 0 | 0 | 0 | 11 | 279 | 57 | 47 | 260 | 0 | 0 | 191 | 43 |
| Peak Hour Factor | 0.92 | 0.92 | 0.92 | 0.39 | 0.95 | 0.89 | 0.78 | 0.91 | 0.92 | 0.92 | 0.87 | 0.68 |
| Hourly flow rate (vph) | 0 | 0 | 0 | 28 | 294 | 64 | 60 | 286 | 0 | 0 | 220 | 63 |
| Direction, Lane # | WB 1 | NB 1 | SB 1 | | | | | | | | | |
| Volume Total (vph) | 386 | 346 | 283 | | | | | | | | | |
| Volume Left (vph) | 28 | 60 | 0 | | | | | | | | | |
| Volume Right (vph) | 64 | 0 | 63 | | | | | | | | | |
| Hadj (s) | -0.05 | 0.07 | -0.10 | | | | | | | | | |
| Departure Headway (s) | 5.6 | 5.6 | 5.5 | | | | | | | | | |
| Degree Utilization, x | 0.60 | 0.54 | 0.44 | | | | | | | | | |
| Capacity (veh/h) | 615 | 606 | 610 | | | | | | | | | |
| Control Delay (s) | 16.4 | 14.9 | 12.7 | | | | | | | | | |
| Approach Delay (s) | 16.4 | 14.9 | 12.7 | | | | | | | | | |
| Approach LOS | C | B | B | | | | | | | | | |
| Intersection Summary | | | | | | | | | | | | |
| Delay | | | 14.9 | | | | | | | | | |
| HCM Level of Service | | | B | | | | | | | | | |
| Intersection Capacity Utilization | | | 57.7% | ICU Level of Service | | | | | | | | B |
| Analysis Period (min) | | | 15 | | | | | | | | | |

HCM Unsignalized Intersection Capacity Analysis
 6: Alley Access East & 10th STREET

AM Peak - Total Future
 7/17/2007



| Movement | EBL | EBR | NBL | NBT | SBT | SBR |
|-----------------------------------|-------------|-------------|-------------|----------------------|------|------|
| Lane Configurations | | | | | | |
| Sign Control | Stop | | | Free | Free | |
| Grade | 0% | | | 0% | 0% | |
| Volume (veh/h) | 17 | 11 | 24 | 69 | 83 | 44 |
| Peak Hour Factor | 0.92 | 0.92 | 0.92 | 0.92 | 0.92 | 0.92 |
| Hourly flow rate (vph) | 18 | 12 | 26 | 75 | 90 | 48 |
| Pedestrians | | | | | | |
| Lane Width (ft) | | | | | | |
| Walking Speed (ft/s) | | | | | | |
| Percent Blockage | | | | | | |
| Right turn flare (veh) | | | | | | |
| Median type | None | | | | | |
| Median storage (veh) | | | | | | |
| Upstream signal (ft) | | | | | 199 | |
| pX, platoon unblocked | | | | | | |
| vC, conflicting volume | 241 | 114 | 138 | | | |
| vC1, stage 1 conf vol | | | | | | |
| vC2, stage 2 conf vol | | | | | | |
| vCu, unblocked vol | 241 | 114 | 138 | | | |
| tC, single (s) | 6.4 | 6.2 | 4.1 | | | |
| tC, 2 stage (s) | | | | | | |
| tF (s) | 3.5 | 3.3 | 2.2 | | | |
| p0 queue free % | 97 | 99 | 98 | | | |
| cM capacity (veh/h) | 734 | 938 | 1446 | | | |
| Direction, Lane # | EB 1 | NB 1 | SB 1 | | | |
| Volume Total | 30 | 101 | 138 | | | |
| Volume Left | 18 | 26 | 0 | | | |
| Volume Right | 12 | 0 | 48 | | | |
| cSH | 802 | 1446 | 1700 | | | |
| Volume to Capacity | 0.04 | 0.02 | 0.08 | | | |
| Queue Length 95th (ft) | 3 | 1 | 0 | | | |
| Control Delay (s) | 9.7 | 2.1 | 0.0 | | | |
| Lane LOS | A | A | | | | |
| Approach Delay (s) | 9.7 | 2.1 | 0.0 | | | |
| Approach LOS | A | | | | | |
| Intersection Summary | | | | | | |
| Average Delay | | | 1.9 | | | |
| Intersection Capacity Utilization | | 25.3% | | ICU Level of Service | | A |
| Analysis Period (min) | | | 15 | | | |

HCM Unsignalized Intersection Capacity Analysis
 7: Alley Access West & 8th STREET

AM Peak - Total Future
 7/17/2007



| Movement | WBL | WBR | NBT | NBR | SBL | SBT |
|------------------------|------|------|------|------|------|------|
| Lane Configurations | ↔ | | ↔ | | ↔ | |
| Sign Control | Stop | | Free | | Free | |
| Grade | 0% | | 0% | | 0% | |
| Volume (veh/h) | 35 | 39 | 284 | 0 | 55 | 200 |
| Peak Hour Factor | 0.92 | 0.92 | 0.92 | 0.92 | 0.92 | 0.92 |
| Hourly flow rate (vph) | 38 | 42 | 309 | 0 | 60 | 217 |
| Pedestrians | | | | | | |
| Lane Width (ft) | | | | | | |
| Walking Speed (ft/s) | | | | | | |
| Percent Blockage | | | | | | |
| Right turn flare (veh) | | | | | | |
| Median type | None | | | | | |
| Median storage (veh) | | | | | | |
| Upstream signal (ft) | 221 | | | | | |
| pX, platoon unblocked | 0.90 | | | | | |
| vC, conflicting volume | 646 | 309 | | | 309 | |
| vC1, stage 1 conf vol | | | | | | |
| vC2, stage 2 conf vol | | | | | | |
| vCu, unblocked vol | 606 | 309 | | | 309 | |
| tC, single (s) | 6.4 | 6.2 | | | 4.1 | |
| tC, 2 stage (s) | | | | | | |
| tF (s) | 3.5 | 3.3 | | | 2.2 | |
| p0 queue free % | 90 | 94 | | | 95 | |
| cM capacity (veh/h) | 394 | 731 | | | 1252 | |

| Direction, Lane # | WB 1 | NB 1 | SB 1 |
|------------------------|------|------|------|
| Volume Total | 80 | 309 | 277 |
| Volume Left | 38 | 0 | 60 |
| Volume Right | 42 | 0 | 0 |
| cSH | 521 | 1700 | 1252 |
| Volume to Capacity | 0.15 | 0.18 | 0.05 |
| Queue Length 95th (ft) | 14 | 0 | 4 |
| Control Delay (s) | 13.2 | 0.0 | 2.1 |
| Lane LOS | B | | A |
| Approach Delay (s) | 13.2 | 0.0 | 2.1 |
| Approach LOS | B | | |

| Intersection Summary | | | |
|-----------------------------------|-------|----------------------|-----|
| Average Delay | | | 2.5 |
| Intersection Capacity Utilization | 42.8% | ICU Level of Service | A |
| Analysis Period (min) | | | 15 |

HCM Signalized Intersection Capacity Analysis
1: H STREET & 8th STREET

PM Peak - Total Future
3/13/2009



| Movement | EBL | EBT | EBR | WBL | WBT | WBR | NBL | NBT | NBR | SBL | SBT | SBR |
|-----------------------------------|------|-------|------|------|------|------|------|------|------|------|-------|------|
| Lane Configurations | | ↕↕ | | | ↕↕ | | | ↕ | | | ↕↕ | |
| Ideal Flow (vphpl) | 1900 | 1900 | 1900 | 1900 | 1900 | 1900 | 1900 | 1900 | 1900 | 1900 | 1900 | 1900 |
| Total Lost time (s) | | 4.0 | | | 4.0 | | | 4.0 | | | 4.0 | |
| Lane Util. Factor | | 0.95 | | | 0.95 | | | 1.00 | | | 1.00 | |
| Fr _t | | 0.98 | | | 0.99 | | | 0.97 | | | 0.98 | |
| Fl _t Protected | | 1.00 | | | 1.00 | | | 1.00 | | | 0.99 | |
| Satd. Flow (prot) | | 3468 | | | 3493 | | | 1802 | | | 1812 | |
| Fl _t Permitted | | 0.89 | | | 1.00 | | | 1.00 | | | 0.46 | |
| Satd. Flow (perm) | | 3080 | | | 3493 | | | 1802 | | | 838 | |
| Volume (vph) | 45 | 1314 | 110 | 0 | 583 | 48 | 0 | 295 | 78 | 41 | 200 | 44 |
| Peak-hour factor, PHF | 0.75 | 0.98 | 0.56 | 0.50 | 0.88 | 0.76 | 0.42 | 0.83 | 0.69 | 0.82 | 0.77 | 0.79 |
| Adj. Flow (vph) | 60 | 1341 | 196 | 0 | 662 | 63 | 0 | 355 | 113 | 50 | 260 | 56 |
| RTOR Reduction (vph) | 0 | 11 | 0 | 0 | 7 | 0 | 0 | 11 | 0 | 0 | 6 | 0 |
| Lane Group Flow (vph) | 0 | 1586 | 0 | 0 | 718 | 0 | 0 | 457 | 0 | 0 | 360 | 0 |
| Turn Type | Perm | | | | | | Perm | | | | | |
| Protected Phases | | 4 | | | 8 | | | 2 | | | 6 | |
| Permitted Phases | 4 | | | | | | | | | 6 | | |
| Actuated Green, G (s) | | 61.0 | | | 61.0 | | | 28.0 | | | 28.0 | |
| Effective Green, g (s) | | 62.0 | | | 62.0 | | | 30.0 | | | 30.0 | |
| Actuated g/C Ratio | | 0.62 | | | 0.62 | | | 0.30 | | | 0.30 | |
| Clearance Time (s) | | 5.0 | | | 5.0 | | | 6.0 | | | 6.0 | |
| Lane Grp Cap (vph) | | 1910 | | | 2166 | | | 541 | | | 251 | |
| v/s Ratio Prot | | | | | 0.21 | | | 0.25 | | | | |
| v/s Ratio Perm | | c0.51 | | | | | | | | | c0.43 | |
| v/c Ratio | | 0.83 | | | 0.33 | | | 0.84 | | | 1.43 | |
| Uniform Delay, d ₁ | | 14.9 | | | 9.1 | | | 32.8 | | | 35.0 | |
| Progression Factor | | 1.00 | | | 0.46 | | | 1.00 | | | 1.00 | |
| Incremental Delay, d ₂ | | 4.4 | | | 0.4 | | | 14.9 | | | 216.3 | |
| Delay (s) | | 19.2 | | | 4.6 | | | 47.7 | | | 251.3 | |
| Level of Service | | B | | | A | | | D | | | F | |
| Approach Delay (s) | | 19.2 | | | 4.6 | | | 47.7 | | | 251.3 | |
| Approach LOS | | B | | | A | | | D | | | F | |

Intersection Summary

| | | | |
|-----------------------------------|--------|----------------------|-----|
| HCM Average Control Delay | 47.0 | HCM Level of Service | D |
| HCM Volume to Capacity ratio | 1.03 | | |
| Actuated Cycle Length (s) | 100.0 | Sum of lost time (s) | 8.0 |
| Intersection Capacity Utilization | 107.8% | ICU Level of Service | G |
| Analysis Period (min) | 15 | | |

c Critical Lane Group

HCM Signalized Intersection Capacity Analysis
2: H STREET & 9th STREET

PM Peak - Total Future
7/17/2007

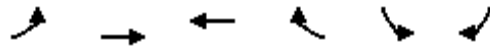

| Movement | EBL | EBT | WBT | WBR | SBL | SBR |
|------------------------|------|-------|------|------|-------|------|
| Lane Configurations | | ↕↕ | ↕↕ | | ↕↕ | |
| Ideal Flow (vphpl) | 1900 | 1900 | 1900 | 1900 | 1900 | 1900 |
| Total Lost time (s) | | 4.0 | 4.0 | | 4.0 | |
| Lane Util. Factor | | 0.95 | 0.95 | | 1.00 | |
| Frt | | 1.00 | 0.98 | | 0.94 | |
| Flt Protected | | 1.00 | 1.00 | | 0.97 | |
| Satd. Flow (prot) | | 3536 | 3484 | | 1703 | |
| Flt Permitted | | 0.93 | 1.00 | | 0.97 | |
| Satd. Flow (perm) | | 3290 | 3484 | | 1703 | |
| Volume (vph) | 15 | 1421 | 623 | 54 | 35 | 18 |
| Peak-hour factor, PHF | 0.54 | 0.93 | 0.90 | 0.67 | 0.89 | 0.56 |
| Adj. Flow (vph) | 28 | 1528 | 692 | 81 | 39 | 32 |
| RTOR Reduction (vph) | 0 | 0 | 9 | 0 | 26 | 0 |
| Lane Group Flow (vph) | 0 | 1556 | 764 | 0 | 45 | 0 |
| Turn Type | Perm | | | | | |
| Protected Phases | | 4 | 8 | | | |
| Permitted Phases | 4 | | | | 6 | |
| Actuated Green, G (s) | | 73.0 | 73.0 | | 16.0 | |
| Effective Green, g (s) | | 74.0 | 74.0 | | 18.0 | |
| Actuated g/C Ratio | | 0.74 | 0.74 | | 0.18 | |
| Clearance Time (s) | | 5.0 | 5.0 | | 6.0 | |
| Lane Grp Cap (vph) | | 2435 | 2578 | | 307 | |
| v/s Ratio Prot | | | 0.22 | | | |
| v/s Ratio Perm | | c0.47 | | | c0.03 | |
| v/c Ratio | | 0.64 | 0.30 | | 0.15 | |
| Uniform Delay, d1 | | 6.4 | 4.3 | | 34.5 | |
| Progression Factor | | 0.39 | 0.66 | | 1.00 | |
| Incremental Delay, d2 | | 0.7 | 0.2 | | 1.0 | |
| Delay (s) | | 3.2 | 3.1 | | 35.5 | |
| Level of Service | | A | A | | D | |
| Approach Delay (s) | | 3.2 | 3.1 | | 35.5 | |
| Approach LOS | | A | A | | D | |

Intersection Summary

| | | | |
|-----------------------------------|-------|----------------------|-----|
| HCM Average Control Delay | 4.1 | HCM Level of Service | A |
| HCM Volume to Capacity ratio | 0.54 | | |
| Actuated Cycle Length (s) | 100.0 | Sum of lost time (s) | 8.0 |
| Intersection Capacity Utilization | 59.8% | ICU Level of Service | B |
| Analysis Period (min) | 15 | | |

c Critical Lane Group

HCM Signalized Intersection Capacity Analysis
 3: H STREET & 10th STREET

PM Peak - Total Future
 7/17/2007



| Movement | EBL | EBT | EBR | WBL | WBT | WBR | NBL | NBT | NBR | SBL | SBT | SBR |
|------------------------|------|-------|------|------|------|------|------|-------|------|------|------|------|
| Lane Configurations | | ↑↑ | | | ↑↑ | | | ↑↓ | | | ↑↓ | |
| Ideal Flow (vphpl) | 1900 | 1900 | 1900 | 1900 | 1900 | 1900 | 1900 | 1900 | 1900 | 1900 | 1900 | 1900 |
| Total Lost time (s) | | 4.0 | | | 4.0 | | | 4.0 | | | 4.0 | |
| Lane Util. Factor | | 0.95 | | | 0.95 | | | 1.00 | | | 1.00 | |
| Frt | | 0.99 | | | 1.00 | | | 0.94 | | | 0.98 | |
| Flt Protected | | 1.00 | | | 0.99 | | | 0.97 | | | 0.99 | |
| Satd. Flow (prot) | | 3516 | | | 3510 | | | 1698 | | | 1798 | |
| Flt Permitted | | 1.00 | | | 0.55 | | | 0.66 | | | 0.88 | |
| Satd. Flow (perm) | | 3516 | | | 1941 | | | 1146 | | | 1600 | |
| Volume (vph) | 0 | 1366 | 53 | 73 | 577 | 0 | 78 | 0 | 55 | 34 | 79 | 19 |
| Peak-hour factor, PHF | 0.25 | 0.96 | 0.83 | 0.59 | 0.92 | 0.25 | 0.82 | 0.25 | 0.63 | 0.77 | 0.78 | 0.66 |
| Adj. Flow (vph) | 0 | 1423 | 64 | 124 | 627 | 0 | 95 | 0 | 87 | 44 | 101 | 29 |
| RTOR Reduction (vph) | 0 | 3 | 0 | 0 | 0 | 0 | 0 | 33 | 0 | 0 | 7 | 0 |
| Lane Group Flow (vph) | 0 | 1484 | 0 | 0 | 751 | 0 | 0 | 149 | 0 | 0 | 167 | 0 |
| Turn Type | | | | Perm | | Perm | | | Perm | | | |
| Protected Phases | | 4 | | | 8 | | | 2 | | | 6 | |
| Permitted Phases | | | | 8 | | | 2 | | | 6 | | |
| Actuated Green, G (s) | | 69.0 | | | 69.0 | | | 20.0 | | | 20.0 | |
| Effective Green, g (s) | | 70.0 | | | 70.0 | | | 22.0 | | | 22.0 | |
| Actuated g/C Ratio | | 0.70 | | | 0.70 | | | 0.22 | | | 0.22 | |
| Clearance Time (s) | | 5.0 | | | 5.0 | | | 6.0 | | | 6.0 | |
| Lane Grp Cap (vph) | | 2461 | | | 1359 | | | 252 | | | 352 | |
| v/s Ratio Prot | | c0.42 | | | | | | | | | | |
| v/s Ratio Perm | | | | | 0.39 | | | c0.13 | | | 0.10 | |
| v/c Ratio | | 0.60 | | | 0.55 | | | 0.59 | | | 0.47 | |
| Uniform Delay, d1 | | 7.8 | | | 7.3 | | | 35.0 | | | 34.0 | |
| Progression Factor | | 0.31 | | | 1.00 | | | 1.00 | | | 1.00 | |
| Incremental Delay, d2 | | 0.9 | | | 1.6 | | | 9.8 | | | 4.5 | |
| Delay (s) | | 3.2 | | | 9.0 | | | 44.8 | | | 38.5 | |
| Level of Service | | A | | | A | | | D | | | D | |
| Approach Delay (s) | | 3.2 | | | 9.0 | | | 44.8 | | | 38.5 | |
| Approach LOS | | A | | | A | | | D | | | D | |

| Intersection Summary | | | |
|-----------------------------------|-------|----------------------|-----|
| HCM Average Control Delay | 10.2 | HCM Level of Service | B |
| HCM Volume to Capacity ratio | 0.60 | | |
| Actuated Cycle Length (s) | 100.0 | Sum of lost time (s) | 8.0 |
| Intersection Capacity Utilization | 81.9% | ICU Level of Service | D |
| Analysis Period (min) | 15 | | |

c Critical Lane Group

HCM Unsignalized Intersection Capacity Analysis
 4: G STREET & 10th STREET

PM Peak - Total Future
 7/17/2007

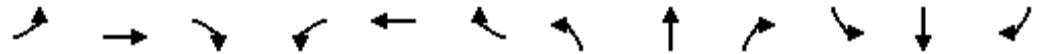

| Movement | EBL | EBT | EBR | WBL | WBT | WBR | NBL | NBT | NBR | SBL | SBT | SBR |
|-----------------------------------|-------|------|-------|----------------------|------|------|------|------|------|------|------|------|
| Lane Configurations | | | | | ↕ | | | ↕ | | | ↕ | |
| Sign Control | Stop | | | Stop | | | Stop | | | Stop | | |
| Volume (vph) | 0 | 0 | 0 | 6 | 73 | 29 | 17 | 105 | 0 | 0 | 97 | 21 |
| Peak Hour Factor | 0.25 | 0.25 | 0.25 | 0.38 | 0.78 | 0.75 | 0.71 | 0.81 | 0.25 | 0.25 | 0.90 | 0.90 |
| Hourly flow rate (vph) | 0 | 0 | 0 | 16 | 94 | 39 | 24 | 130 | 0 | 0 | 108 | 23 |
| Direction, Lane # | WB 1 | NB 1 | SB 1 | | | | | | | | | |
| Volume Total (vph) | 148 | 154 | 131 | | | | | | | | | |
| Volume Left (vph) | 16 | 24 | 0 | | | | | | | | | |
| Volume Right (vph) | 39 | 0 | 23 | | | | | | | | | |
| Hadj (s) | -0.10 | 0.07 | -0.07 | | | | | | | | | |
| Departure Headway (s) | 4.4 | 4.5 | 4.4 | | | | | | | | | |
| Degree Utilization, x | 0.18 | 0.19 | 0.16 | | | | | | | | | |
| Capacity (veh/h) | 757 | 773 | 785 | | | | | | | | | |
| Control Delay (s) | 8.4 | 8.5 | 8.2 | | | | | | | | | |
| Approach Delay (s) | 8.4 | 8.5 | 8.2 | | | | | | | | | |
| Approach LOS | A | A | A | | | | | | | | | |
| Intersection Summary | | | | | | | | | | | | |
| Delay | | | 8.4 | | | | | | | | | |
| HCM Level of Service | | | A | | | | | | | | | |
| Intersection Capacity Utilization | | | 25.7% | ICU Level of Service | | | | | | | | A |
| Analysis Period (min) | | | 15 | | | | | | | | | |

HCM Unsignalized Intersection Capacity Analysis
 5: G STREET & 8th STREET

PM Peak - Total Future
 7/17/2007

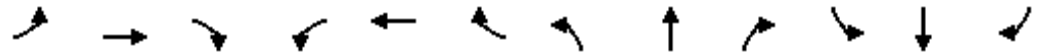

| Movement | EBL | EBT | EBR | WBL | WBT | WBR | NBL | NBT | NBR | SBL | SBT | SBR |
|------------------------|------|------|------|------|------|------|------|------|------|------|------|------|
| Lane Configurations | | | | | ↔ | | | ↔ | | | ↔ | |
| Sign Control | Stop | | | Stop | | | Stop | | | Stop | | |
| Volume (vph) | 0 | 0 | 0 | 7 | 87 | 48 | 27 | 250 | 0 | 0 | 237 | 81 |
| Peak Hour Factor | 0.25 | 0.25 | 0.25 | 0.58 | 0.74 | 0.71 | 0.75 | 0.94 | 0.25 | 0.25 | 0.90 | 0.40 |
| Hourly flow rate (vph) | 0 | 0 | 0 | 12 | 118 | 68 | 36 | 266 | 0 | 0 | 263 | 202 |

| Direction, Lane # | WB 1 | NB 1 | SB 1 |
|-----------------------|-------|------|-------|
| Volume Total (vph) | 197 | 302 | 466 |
| Volume Left (vph) | 12 | 36 | 0 |
| Volume Right (vph) | 68 | 0 | 203 |
| Hadj (s) | -0.16 | 0.06 | -0.23 |
| Departure Headway (s) | 5.6 | 5.1 | 4.7 |
| Degree Utilization, x | 0.30 | 0.43 | 0.61 |
| Capacity (veh/h) | 586 | 673 | 746 |
| Control Delay (s) | 11.0 | 12.0 | 14.6 |
| Approach Delay (s) | 11.0 | 12.0 | 14.6 |
| Approach LOS | B | B | B |

| Intersection Summary | | |
|-----------------------------------|-------|----------------------|
| Delay | | 13.0 |
| HCM Level of Service | | B |
| Intersection Capacity Utilization | 49.9% | ICU Level of Service |
| Analysis Period (min) | | 15 |
| | | A |



| Movement | EBL | EBR | NBL | NBT | SBT | SBR |
|-----------------------------------|-------------|-------------|-------------|----------------------|------|------|
| Lane Configurations | | | | | | |
| Sign Control | Stop | | | Free | Free | |
| Grade | 0% | | | 0% | 0% | |
| Volume (veh/h) | 18 | 13 | 39 | 69 | 83 | 85 |
| Peak Hour Factor | 0.92 | 0.92 | 0.92 | 0.92 | 0.92 | 0.92 |
| Hourly flow rate (vph) | 20 | 14 | 42 | 75 | 90 | 92 |
| Pedestrians | | | | | | |
| Lane Width (ft) | | | | | | |
| Walking Speed (ft/s) | | | | | | |
| Percent Blockage | | | | | | |
| Right turn flare (veh) | | | | | | |
| Median type | None | | | | | |
| Median storage (veh) | | | | | | |
| Upstream signal (ft) | | | | | 199 | |
| pX, platoon unblocked | | | | | | |
| vC, conflicting volume | 296 | 136 | 183 | | | |
| vC1, stage 1 conf vol | | | | | | |
| vC2, stage 2 conf vol | | | | | | |
| vCu, unblocked vol | 296 | 136 | 183 | | | |
| tC, single (s) | 6.4 | 6.2 | 4.1 | | | |
| tC, 2 stage (s) | | | | | | |
| tF (s) | 3.5 | 3.3 | 2.2 | | | |
| p0 queue free % | 97 | 98 | 97 | | | |
| cM capacity (veh/h) | 674 | 912 | 1392 | | | |
| Direction, Lane # | EB 1 | NB 1 | SB 1 | | | |
| Volume Total | 34 | 117 | 183 | | | |
| Volume Left | 20 | 42 | 0 | | | |
| Volume Right | 14 | 0 | 92 | | | |
| cSH | 757 | 1392 | 1700 | | | |
| Volume to Capacity | 0.04 | 0.03 | 0.11 | | | |
| Queue Length 95th (ft) | 3 | 2 | 0 | | | |
| Control Delay (s) | 10.0 | 2.9 | 0.0 | | | |
| Lane LOS | A | A | | | | |
| Approach Delay (s) | 10.0 | 2.9 | 0.0 | | | |
| Approach LOS | A | | | | | |
| Intersection Summary | | | | | | |
| Average Delay | | | 2.0 | | | |
| Intersection Capacity Utilization | | 28.7% | | ICU Level of Service | | A |
| Analysis Period (min) | | | 15 | | | |

HCM Unsignalized Intersection Capacity Analysis
7: Alley Access West & 8th STREET

PM Peak - Total Future
7/17/2007



| Movement | WBL | WBR | NBT | NBR | SBL | SBT |
|------------------------|------|------|------|------|------|------|
| Lane Configurations | ↔ | | ↔ | | | ↔ |
| Sign Control | Stop | | Free | | | Free |
| Grade | 0% | | 0% | | | 0% |
| Volume (veh/h) | 105 | 126 | 271 | 28 | 109 | 212 |
| Peak Hour Factor | 0.92 | 0.92 | 0.92 | 0.92 | 0.92 | 0.92 |
| Hourly flow rate (vph) | 114 | 137 | 295 | 30 | 118 | 230 |
| Pedestrians | | | | | | |
| Lane Width (ft) | | | | | | |
| Walking Speed (ft/s) | | | | | | |
| Percent Blockage | | | | | | |
| Right turn flare (veh) | | | | | | |
| Median type | None | | | | | |
| Median storage (veh) | | | | | | |
| Upstream signal (ft) | | | | | | 221 |
| pX, platoon unblocked | | | | | | |
| vC, conflicting volume | 777 | 310 | | | 325 | |
| vC1, stage 1 conf vol | | | | | | |
| vC2, stage 2 conf vol | | | | | | |
| vCu, unblocked vol | 777 | 310 | | | 325 | |
| tC, single (s) | 6.4 | 6.2 | | | 4.1 | |
| tC, 2 stage (s) | | | | | | |
| tF (s) | 3.5 | 3.3 | | | 2.2 | |
| p0 queue free % | 65 | 81 | | | 90 | |
| cM capacity (veh/h) | 330 | 730 | | | 1235 | |

| Direction, Lane # | WB 1 | NB 1 | SB 1 |
|------------------------|------|------|------|
| Volume Total | 251 | 325 | 349 |
| Volume Left | 114 | 0 | 118 |
| Volume Right | 137 | 30 | 0 |
| cSH | 471 | 1700 | 1235 |
| Volume to Capacity | 0.53 | 0.19 | 0.10 |
| Queue Length 95th (ft) | 77 | 0 | 8 |
| Control Delay (s) | 21.0 | 0.0 | 3.4 |
| Lane LOS | C | | A |
| Approach Delay (s) | 21.0 | 0.0 | 3.4 |
| Approach LOS | C | | |

| Intersection Summary | | | |
|-----------------------------------|-------|----------------------|---|
| Average Delay | | 7.0 | |
| Intersection Capacity Utilization | 56.7% | ICU Level of Service | B |
| Analysis Period (min) | | 15 | |

HCM Signalized Intersection Capacity Analysis
1: H STREET & 8th STREET

AM Peak - Total Future_IMP
7/17/2007



| Movement | EBL | EBT | EBR | WBL | WBT | WBR | NBL | NBT | NBR | SBL | SBT | SBR |
|-----------------------------------|------|------|------|------|-------|------|------|-------|------|------|------|------|
| Lane Configurations | | ↕↕ | | | ↕↕ | | | ↕ | | | ↕↕ | |
| Ideal Flow (vphpl) | 1900 | 1900 | 1900 | 1900 | 1900 | 1900 | 1900 | 1900 | 1900 | 1900 | 1900 | 1900 |
| Total Lost time (s) | | 4.0 | | | 4.0 | | | 4.0 | | | 4.0 | |
| Lane Util. Factor | | 0.95 | | | 0.95 | | | 1.00 | | | 1.00 | |
| Fr _t | | 0.97 | | | 1.00 | | | 0.98 | | | 0.98 | |
| Fl _t Protected | | 1.00 | | | 1.00 | | | 1.00 | | | 1.00 | |
| Satd. Flow (prot) | | 3439 | | | 3531 | | | 1823 | | | 1827 | |
| Fl _t Permitted | | 0.68 | | | 1.00 | | | 1.00 | | | 0.92 | |
| Satd. Flow (perm) | | 2338 | | | 3531 | | | 1823 | | | 1692 | |
| Volume (vph) | 23 | 417 | 57 | 0 | 1767 | 29 | 0 | 207 | 26 | 14 | 192 | 25 |
| Peak-hour factor, PHF | 0.58 | 0.86 | 0.54 | 0.25 | 0.94 | 1.00 | 0.50 | 0.82 | 0.54 | 0.67 | 0.86 | 0.78 |
| Adj. Flow (vph) | 40 | 485 | 106 | 0 | 1880 | 29 | 0 | 252 | 48 | 21 | 223 | 32 |
| RTOR Reduction (vph) | 0 | 17 | 0 | 0 | 1 | 0 | 0 | 7 | 0 | 0 | 4 | 0 |
| Lane Group Flow (vph) | 0 | 614 | 0 | 0 | 1908 | 0 | 0 | 293 | 0 | 0 | 272 | 0 |
| Turn Type | Perm | | | | | | Perm | | | | | |
| Protected Phases | | 4 | | | 8 | | | 2 | | | 6 | |
| Permitted Phases | 4 | | | | | | | | | 6 | | |
| Actuated Green, G (s) | | 63.0 | | | 63.0 | | | 25.0 | | | 25.0 | |
| Effective Green, g (s) | | 65.0 | | | 65.0 | | | 27.0 | | | 27.0 | |
| Actuated g/C Ratio | | 0.65 | | | 0.65 | | | 0.27 | | | 0.27 | |
| Clearance Time (s) | | 6.0 | | | 6.0 | | | 6.0 | | | 6.0 | |
| Lane Grp Cap (vph) | | 1520 | | | 2295 | | | 492 | | | 457 | |
| v/s Ratio Prot | | | | | c0.54 | | | c0.16 | | | | |
| v/s Ratio Perm | | 0.26 | | | | | | | | | 0.16 | |
| v/c Ratio | | 0.40 | | | 0.83 | | | 0.60 | | | 0.59 | |
| Uniform Delay, d ₁ | | 8.3 | | | 13.3 | | | 31.8 | | | 31.7 | |
| Progression Factor | | 1.00 | | | 0.31 | | | 1.00 | | | 1.00 | |
| Incremental Delay, d ₂ | | 0.8 | | | 2.1 | | | 5.3 | | | 5.6 | |
| Delay (s) | | 9.1 | | | 6.2 | | | 37.0 | | | 37.3 | |
| Level of Service | | A | | | A | | | D | | | D | |
| Approach Delay (s) | | 9.1 | | | 6.2 | | | 37.0 | | | 37.3 | |
| Approach LOS | | A | | | A | | | D | | | D | |

Intersection Summary

| | | | |
|-----------------------------------|-------|----------------------|-----|
| HCM Average Control Delay | 12.5 | HCM Level of Service | B |
| HCM Volume to Capacity ratio | 0.76 | | |
| Actuated Cycle Length (s) | 100.0 | Sum of lost time (s) | 8.0 |
| Intersection Capacity Utilization | 79.7% | ICU Level of Service | D |
| Analysis Period (min) | 15 | | |

c Critical Lane Group

HCM Signalized Intersection Capacity Analysis
2: H STREET & 9th STREET

AM Peak - Total Future_IMP
7/17/2007

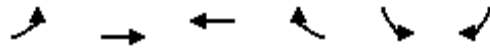

| Movement | EBL | EBT | WBT | WBR | SBL | SBR |
|------------------------|------|------|-------|------|-------|------|
| Lane Configurations | | ↕↕ | ↕↕ | | ↕↕ | |
| Ideal Flow (vphpl) | 1900 | 1900 | 1900 | 1900 | 1900 | 1900 |
| Total Lost time (s) | | 4.0 | 4.0 | | 4.0 | |
| Lane Util. Factor | | 0.95 | 0.95 | | 1.00 | |
| Frt | | 1.00 | 0.99 | | 0.95 | |
| Flt Protected | | 1.00 | 1.00 | | 0.97 | |
| Satd. Flow (prot) | | 3534 | 3513 | | 1715 | |
| Flt Permitted | | 0.85 | 1.00 | | 0.97 | |
| Satd. Flow (perm) | | 2993 | 3513 | | 1715 | |
| Volume (vph) | 7 | 452 | 1786 | 83 | 16 | 9 |
| Peak-hour factor, PHF | 0.44 | 0.93 | 0.89 | 0.80 | 0.81 | 0.75 |
| Adj. Flow (vph) | 16 | 486 | 2007 | 104 | 20 | 12 |
| RTOR Reduction (vph) | 0 | 0 | 4 | 0 | 10 | 0 |
| Lane Group Flow (vph) | 0 | 502 | 2107 | 0 | 22 | 0 |
| Turn Type | Perm | | | | | |
| Protected Phases | | 4 | 8 | | | |
| Permitted Phases | 4 | | | | 6 | |
| Actuated Green, G (s) | | 71.0 | 71.0 | | 18.0 | |
| Effective Green, g (s) | | 73.0 | 73.0 | | 19.0 | |
| Actuated g/C Ratio | | 0.73 | 0.73 | | 0.19 | |
| Clearance Time (s) | | 6.0 | 6.0 | | 5.0 | |
| Lane Grp Cap (vph) | | 2185 | 2564 | | 326 | |
| v/s Ratio Prot | | | c0.60 | | | |
| v/s Ratio Perm | | 0.17 | | | c0.01 | |
| v/c Ratio | | 0.23 | 0.82 | | 0.07 | |
| Uniform Delay, d1 | | 4.4 | 9.1 | | 33.2 | |
| Progression Factor | | 0.67 | 0.29 | | 1.00 | |
| Incremental Delay, d2 | | 0.2 | 1.9 | | 0.4 | |
| Delay (s) | | 3.1 | 4.5 | | 33.6 | |
| Level of Service | | A | A | | C | |
| Approach Delay (s) | | 3.1 | 4.5 | | 33.6 | |
| Approach LOS | | A | A | | C | |

Intersection Summary

| | | | |
|-----------------------------------|-------|----------------------|-----|
| HCM Average Control Delay | 4.6 | HCM Level of Service | A |
| HCM Volume to Capacity ratio | 0.67 | | |
| Actuated Cycle Length (s) | 100.0 | Sum of lost time (s) | 8.0 |
| Intersection Capacity Utilization | 62.0% | ICU Level of Service | B |
| Analysis Period (min) | 15 | | |

c Critical Lane Group

HCM Signalized Intersection Capacity Analysis
3: H STREET & 10th STREET

AM Peak - Total Future_IMP
7/17/2007



| Movement | EBL | EBT | EBR | WBL | WBT | WBR | NBL | NBT | NBR | SBL | SBT | SBR |
|-----------------------------------|------|------|------|------|-------|------|------|-------|------|------|------|------|
| Lane Configurations | | ↑↑ | | | ↑↑ | | | ↑↓ | | | ↑↓ | |
| Ideal Flow (vphpl) | 1900 | 1900 | 1900 | 1900 | 1900 | 1900 | 1900 | 1900 | 1900 | 1900 | 1900 | 1900 |
| Total Lost time (s) | | 4.0 | | | 4.0 | | | 4.0 | | | 4.0 | |
| Lane Util. Factor | | 0.95 | | | 0.95 | | | 1.00 | | | 1.00 | |
| Fr _t | | 0.99 | | | 1.00 | | | 0.97 | | | 0.98 | |
| Fl _t Protected | | 1.00 | | | 1.00 | | | 0.96 | | | 0.99 | |
| Satd. Flow (prot) | | 3487 | | | 3534 | | | 1744 | | | 1813 | |
| Fl _t Permitted | | 1.00 | | | 0.91 | | | 0.70 | | | 0.95 | |
| Satd. Flow (perm) | | 3487 | | | 3237 | | | 1272 | | | 1739 | |
| Volume (vph) | 0 | 438 | 33 | 35 | 1793 | 0 | 68 | 0 | 16 | 7 | 51 | 7 |
| Peak-hour factor, PHF | 0.92 | 0.92 | 0.64 | 0.58 | 0.93 | 0.92 | 0.65 | 0.92 | 0.63 | 0.58 | 0.88 | 0.56 |
| Adj. Flow (vph) | 0 | 476 | 52 | 60 | 1928 | 0 | 105 | 0 | 25 | 12 | 58 | 12 |
| RTOR Reduction (vph) | 0 | 8 | 0 | 0 | 0 | 0 | 0 | 8 | 0 | 0 | 7 | 0 |
| Lane Group Flow (vph) | 0 | 520 | 0 | 0 | 1988 | 0 | 0 | 122 | 0 | 0 | 75 | 0 |
| Turn Type | | | | Perm | | Perm | | | Perm | | | |
| Protected Phases | | 4 | | | 8 | | | 2 | | | 6 | |
| Permitted Phases | | | | 8 | | | 2 | | | 6 | | |
| Actuated Green, G (s) | | 72.0 | | | 72.0 | | | 16.0 | | | 16.0 | |
| Effective Green, g (s) | | 74.0 | | | 74.0 | | | 18.0 | | | 18.0 | |
| Actuated g/C Ratio | | 0.74 | | | 0.74 | | | 0.18 | | | 0.18 | |
| Clearance Time (s) | | 6.0 | | | 6.0 | | | 6.0 | | | 6.0 | |
| Lane Grp Cap (vph) | | 2580 | | | 2395 | | | 229 | | | 313 | |
| v/s Ratio Prot | | 0.15 | | | | | | | | | | |
| v/s Ratio Perm | | | | | c0.61 | | | c0.10 | | | 0.04 | |
| v/c Ratio | | 0.20 | | | 0.83 | | | 0.53 | | | 0.24 | |
| Uniform Delay, d ₁ | | 4.0 | | | 8.8 | | | 37.2 | | | 35.1 | |
| Progression Factor | | 0.60 | | | 1.00 | | | 1.00 | | | 1.00 | |
| Incremental Delay, d ₂ | | 0.2 | | | 3.5 | | | 8.6 | | | 1.8 | |
| Delay (s) | | 2.6 | | | 12.3 | | | 45.8 | | | 37.0 | |
| Level of Service | | A | | | B | | | D | | | D | |
| Approach Delay (s) | | 2.6 | | | 12.3 | | | 45.8 | | | 37.0 | |
| Approach LOS | | A | | | B | | | D | | | D | |

Intersection Summary

| | | | |
|-----------------------------------|-------|----------------------|-----|
| HCM Average Control Delay | 12.7 | HCM Level of Service | B |
| HCM Volume to Capacity ratio | 0.77 | | |
| Actuated Cycle Length (s) | 100.0 | Sum of lost time (s) | 8.0 |
| Intersection Capacity Utilization | 85.1% | ICU Level of Service | E |
| Analysis Period (min) | 15 | | |

c Critical Lane Group

HCM Unsignalized Intersection Capacity Analysis
 4: G STREET & 10th STREET

AM Peak - Total Future_IMP
 7/17/2007



| Movement | EBL | EBT | EBR | WBL | WBT | WBR | NBL | NBT | NBR | SBL | SBT | SBR |
|------------------------|------|------|------|------|------|------|------|------|------|------|------|------|
| Lane Configurations | | | | | ↕ | | | ↕ | | | ↕ | |
| Sign Control | Stop | | | Stop | | | Stop | | | Stop | | |
| Volume (vph) | 0 | 0 | 0 | 5 | 234 | 25 | 33 | 67 | 0 | 0 | 76 | 26 |
| Peak Hour Factor | 0.90 | 0.90 | 0.90 | 0.63 | 0.92 | 0.68 | 0.83 | 0.63 | 0.92 | 0.92 | 0.79 | 0.75 |
| Hourly flow rate (vph) | 0 | 0 | 0 | 8 | 254 | 37 | 40 | 106 | 0 | 0 | 96 | 35 |

| Direction, Lane # | WB 1 | NB 1 | SB 1 |
|-----------------------|-------|------|-------|
| Volume Total (vph) | 299 | 146 | 131 |
| Volume Left (vph) | 8 | 40 | 0 |
| Volume Right (vph) | 37 | 0 | 35 |
| Hadj (s) | -0.03 | 0.09 | -0.12 |
| Departure Headway (s) | 4.5 | 4.9 | 4.7 |
| Degree Utilization, x | 0.38 | 0.20 | 0.17 |
| Capacity (veh/h) | 751 | 690 | 710 |
| Control Delay (s) | 10.3 | 9.1 | 8.7 |
| Approach Delay (s) | 10.3 | 9.1 | 8.7 |
| Approach LOS | B | A | A |

| Intersection Summary | | |
|-----------------------------------|-------|----------------------|
| Delay | | 9.6 |
| HCM Level of Service | | A |
| Intersection Capacity Utilization | 32.8% | ICU Level of Service |
| Analysis Period (min) | | 15 |

HCM Unsignalized Intersection Capacity Analysis
 5: G STREET & 8th STREET

AM Peak - Total Future_IMP
 7/17/2007

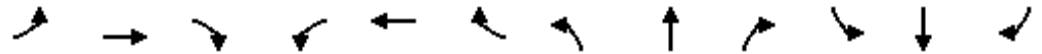

| Movement | EBL | EBT | EBR | WBL | WBT | WBR | NBL | NBT | NBR | SBL | SBT | SBR |
|-----------------------------------|-------------|-------------|-------------|----------------------|------|------|------|------|------|------|------|------|
| Lane Configurations | | | | | ↔ | | | ↔ | | | ↔ | |
| Sign Control | Stop | | | Stop | | | Stop | | | Stop | | |
| Volume (vph) | 0 | 0 | 0 | 11 | 279 | 57 | 47 | 260 | 0 | 0 | 191 | 43 |
| Peak Hour Factor | 0.92 | 0.92 | 0.92 | 0.39 | 0.95 | 0.89 | 0.78 | 0.91 | 0.92 | 0.92 | 0.87 | 0.68 |
| Hourly flow rate (vph) | 0 | 0 | 0 | 28 | 294 | 64 | 60 | 286 | 0 | 0 | 220 | 63 |
| Direction, Lane # | WB 1 | NB 1 | SB 1 | | | | | | | | | |
| Volume Total (vph) | 386 | 346 | 283 | | | | | | | | | |
| Volume Left (vph) | 28 | 60 | 0 | | | | | | | | | |
| Volume Right (vph) | 64 | 0 | 63 | | | | | | | | | |
| Hadj (s) | -0.05 | 0.07 | -0.10 | | | | | | | | | |
| Departure Headway (s) | 5.6 | 5.6 | 5.5 | | | | | | | | | |
| Degree Utilization, x | 0.60 | 0.54 | 0.44 | | | | | | | | | |
| Capacity (veh/h) | 615 | 606 | 610 | | | | | | | | | |
| Control Delay (s) | 16.4 | 14.9 | 12.7 | | | | | | | | | |
| Approach Delay (s) | 16.4 | 14.9 | 12.7 | | | | | | | | | |
| Approach LOS | C | B | B | | | | | | | | | |
| Intersection Summary | | | | | | | | | | | | |
| Delay | | | 14.9 | | | | | | | | | |
| HCM Level of Service | | | B | | | | | | | | | |
| Intersection Capacity Utilization | | | 57.7% | ICU Level of Service | | | | | | | | B |
| Analysis Period (min) | | | 15 | | | | | | | | | |



| Movement | EBL | EBR | NBL | NBT | SBT | SBR |
|-----------------------------------|-------------|-------------|-------------|----------------------|------|------|
| Lane Configurations | | | | | | |
| Sign Control | Stop | | | Free | Free | |
| Grade | 0% | | | 0% | 0% | |
| Volume (veh/h) | 17 | 11 | 24 | 69 | 83 | 44 |
| Peak Hour Factor | 0.92 | 0.92 | 0.92 | 0.92 | 0.92 | 0.92 |
| Hourly flow rate (vph) | 18 | 12 | 26 | 75 | 90 | 48 |
| Pedestrians | | | | | | |
| Lane Width (ft) | | | | | | |
| Walking Speed (ft/s) | | | | | | |
| Percent Blockage | | | | | | |
| Right turn flare (veh) | | | | | | |
| Median type | None | | | | | |
| Median storage (veh) | | | | | | |
| Upstream signal (ft) | | | | | 199 | |
| pX, platoon unblocked | | | | | | |
| vC, conflicting volume | 241 | 114 | 138 | | | |
| vC1, stage 1 conf vol | | | | | | |
| vC2, stage 2 conf vol | | | | | | |
| vCu, unblocked vol | 241 | 114 | 138 | | | |
| tC, single (s) | 6.4 | 6.2 | 4.1 | | | |
| tC, 2 stage (s) | | | | | | |
| tF (s) | 3.5 | 3.3 | 2.2 | | | |
| p0 queue free % | 97 | 99 | 98 | | | |
| cM capacity (veh/h) | 734 | 938 | 1446 | | | |
| Direction, Lane # | EB 1 | NB 1 | SB 1 | | | |
| Volume Total | 30 | 101 | 138 | | | |
| Volume Left | 18 | 26 | 0 | | | |
| Volume Right | 12 | 0 | 48 | | | |
| cSH | 802 | 1446 | 1700 | | | |
| Volume to Capacity | 0.04 | 0.02 | 0.08 | | | |
| Queue Length 95th (ft) | 3 | 1 | 0 | | | |
| Control Delay (s) | 9.7 | 2.1 | 0.0 | | | |
| Lane LOS | A | A | | | | |
| Approach Delay (s) | 9.7 | 2.1 | 0.0 | | | |
| Approach LOS | A | | | | | |
| Intersection Summary | | | | | | |
| Average Delay | | | 1.9 | | | |
| Intersection Capacity Utilization | | 25.3% | | ICU Level of Service | | A |
| Analysis Period (min) | | | 15 | | | |

HCM Unsignalized Intersection Capacity Analysis
7: Alley Access West & 8th STREET

AM Peak - Total Future_IMP
7/17/2007



| Movement | WBL | WBR | NBT | NBR | SBL | SBT |
|-----------------------------------|-------------|-------------|-------------|----------------------|------|------|
| Lane Configurations | ↔ | | ↔ | | ↔ | |
| Sign Control | Stop | | Free | | Free | |
| Grade | 0% | | 0% | | 0% | |
| Volume (veh/h) | 35 | 39 | 284 | 0 | 55 | 200 |
| Peak Hour Factor | 0.92 | 0.92 | 0.92 | 0.92 | 0.92 | 0.92 |
| Hourly flow rate (vph) | 38 | 42 | 309 | 0 | 60 | 217 |
| Pedestrians | | | | | | |
| Lane Width (ft) | | | | | | |
| Walking Speed (ft/s) | | | | | | |
| Percent Blockage | | | | | | |
| Right turn flare (veh) | | | | | | |
| Median type | None | | | | | |
| Median storage (veh) | | | | | | |
| Upstream signal (ft) | 221 | | | | | |
| pX, platoon unblocked | 0.91 | | | | | |
| vC, conflicting volume | 646 | 309 | | | 309 | |
| vC1, stage 1 conf vol | | | | | | |
| vC2, stage 2 conf vol | | | | | | |
| vCu, unblocked vol | 609 | 309 | | | 309 | |
| tC, single (s) | 6.4 | 6.2 | | | 4.1 | |
| tC, 2 stage (s) | | | | | | |
| tF (s) | 3.5 | 3.3 | | | 2.2 | |
| p0 queue free % | 90 | 94 | | | 95 | |
| cM capacity (veh/h) | 395 | 731 | | | 1252 | |
| Direction, Lane # | WB 1 | NB 1 | SB 1 | | | |
| Volume Total | 80 | 309 | 277 | | | |
| Volume Left | 38 | 0 | 60 | | | |
| Volume Right | 42 | 0 | 0 | | | |
| cSH | 522 | 1700 | 1252 | | | |
| Volume to Capacity | 0.15 | 0.18 | 0.05 | | | |
| Queue Length 95th (ft) | 14 | 0 | 4 | | | |
| Control Delay (s) | 13.2 | 0.0 | 2.1 | | | |
| Lane LOS | B | | A | | | |
| Approach Delay (s) | 13.2 | 0.0 | 2.1 | | | |
| Approach LOS | B | | | | | |
| Intersection Summary | | | | | | |
| Average Delay | | | 2.5 | | | |
| Intersection Capacity Utilization | | | 42.8% | ICU Level of Service | A | |
| Analysis Period (min) | | | 15 | | | |

HCM Signalized Intersection Capacity Analysis
 1: H STREET & 8th STREET

PM Peak - Total Future_IMP
 7/17/2007



| Movement | EBL | EBT | EBR | WBL | WBT | WBR | NBL | NBT | NBR | SBL | SBT | SBR |
|------------------------|------|-------|------|------|------|------|------|------|------|------|-------|------|
| Lane Configurations | | ↕↕ | | | ↕↕ | | | ↕ | | | ↕↕ | |
| Ideal Flow (vphpl) | 1900 | 1900 | 1900 | 1900 | 1900 | 1900 | 1900 | 1900 | 1900 | 1900 | 1900 | 1900 |
| Total Lost time (s) | | 4.0 | | | 4.0 | | | 4.0 | | | 4.0 | |
| Lane Util. Factor | | 0.95 | | | 0.95 | | | 1.00 | | | 1.00 | |
| Frt | | 0.98 | | | 0.99 | | | 0.97 | | | 0.98 | |
| Flt Protected | | 1.00 | | | 1.00 | | | 1.00 | | | 0.99 | |
| Satd. Flow (prot) | | 3468 | | | 3493 | | | 1802 | | | 1812 | |
| Flt Permitted | | 0.89 | | | 1.00 | | | 1.00 | | | 0.66 | |
| Satd. Flow (perm) | | 3078 | | | 3493 | | | 1802 | | | 1199 | |
| Volume (vph) | 45 | 1314 | 110 | 0 | 583 | 48 | 0 | 295 | 78 | 41 | 200 | 44 |
| Peak-hour factor, PHF | 0.75 | 0.98 | 0.56 | 0.50 | 0.88 | 0.76 | 0.42 | 0.83 | 0.69 | 0.82 | 0.77 | 0.79 |
| Adj. Flow (vph) | 60 | 1341 | 196 | 0 | 662 | 63 | 0 | 355 | 113 | 50 | 260 | 56 |
| RTOR Reduction (vph) | 0 | 11 | 0 | 0 | 7 | 0 | 0 | 11 | 0 | 0 | 6 | 0 |
| Lane Group Flow (vph) | 0 | 1586 | 0 | 0 | 718 | 0 | 0 | 457 | 0 | 0 | 360 | 0 |
| Turn Type | Perm | | | | | | Perm | | | | | |
| Protected Phases | | 4 | | | 8 | | | 2 | | | 6 | |
| Permitted Phases | 4 | | | | | | | | | 6 | | |
| Actuated Green, G (s) | | 54.0 | | | 54.0 | | | 35.0 | | | 35.0 | |
| Effective Green, g (s) | | 55.0 | | | 55.0 | | | 37.0 | | | 37.0 | |
| Actuated g/C Ratio | | 0.55 | | | 0.55 | | | 0.37 | | | 0.37 | |
| Clearance Time (s) | | 5.0 | | | 5.0 | | | 6.0 | | | 6.0 | |
| Lane Grp Cap (vph) | | 1693 | | | 1921 | | | 667 | | | 444 | |
| v/s Ratio Prot | | | | | 0.21 | | | 0.25 | | | | |
| v/s Ratio Perm | | c0.52 | | | | | | | | | c0.30 | |
| v/c Ratio | | 0.94 | | | 0.37 | | | 0.68 | | | 0.81 | |
| Uniform Delay, d1 | | 20.9 | | | 12.7 | | | 26.6 | | | 28.3 | |
| Progression Factor | | 1.00 | | | 0.52 | | | 1.00 | | | 1.00 | |
| Incremental Delay, d2 | | 11.3 | | | 0.5 | | | 5.6 | | | 14.8 | |
| Delay (s) | | 32.2 | | | 7.2 | | | 32.2 | | | 43.1 | |
| Level of Service | | C | | | A | | | C | | | D | |
| Approach Delay (s) | | 32.2 | | | 7.2 | | | 32.2 | | | 43.1 | |
| Approach LOS | | C | | | A | | | C | | | D | |

Intersection Summary

| | | | |
|-----------------------------------|--------|----------------------|-----|
| HCM Average Control Delay | 27.7 | HCM Level of Service | C |
| HCM Volume to Capacity ratio | 0.89 | | |
| Actuated Cycle Length (s) | 100.0 | Sum of lost time (s) | 8.0 |
| Intersection Capacity Utilization | 107.8% | ICU Level of Service | G |
| Analysis Period (min) | 15 | | |

c Critical Lane Group

HCM Signalized Intersection Capacity Analysis
 2: H STREET & 9th STREET

PM Peak - Total Future_IMP
 7/17/2007

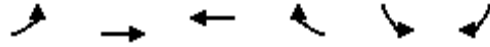

| Movement | EBL | EBT | WBT | WBR | SBL | SBR |
|------------------------|------|-------|------|------|-------|------|
| Lane Configurations | | ↕↕ | ↕↕ | | ↕↕ | |
| Ideal Flow (vphpl) | 1900 | 1900 | 1900 | 1900 | 1900 | 1900 |
| Total Lost time (s) | | 4.0 | 4.0 | | 4.0 | |
| Lane Util. Factor | | 0.95 | 0.95 | | 1.00 | |
| Frt | | 1.00 | 0.98 | | 0.94 | |
| Flt Protected | | 1.00 | 1.00 | | 0.97 | |
| Satd. Flow (prot) | | 3536 | 3484 | | 1703 | |
| Flt Permitted | | 0.93 | 1.00 | | 0.97 | |
| Satd. Flow (perm) | | 3289 | 3484 | | 1703 | |
| Volume (vph) | 15 | 1421 | 623 | 54 | 35 | 18 |
| Peak-hour factor, PHF | 0.54 | 0.93 | 0.90 | 0.67 | 0.89 | 0.56 |
| Adj. Flow (vph) | 28 | 1528 | 692 | 81 | 39 | 32 |
| RTOR Reduction (vph) | 0 | 0 | 9 | 0 | 24 | 0 |
| Lane Group Flow (vph) | 0 | 1556 | 764 | 0 | 47 | 0 |
| Turn Type | | Perm | | | | |
| Protected Phases | | 4 | 8 | | | |
| Permitted Phases | 4 | | | | 6 | |
| Actuated Green, G (s) | | 66.0 | 66.0 | | 23.0 | |
| Effective Green, g (s) | | 67.0 | 67.0 | | 25.0 | |
| Actuated g/C Ratio | | 0.67 | 0.67 | | 0.25 | |
| Clearance Time (s) | | 5.0 | 5.0 | | 6.0 | |
| Lane Grp Cap (vph) | | 2204 | 2334 | | 426 | |
| v/s Ratio Prot | | | 0.22 | | | |
| v/s Ratio Perm | | c0.47 | | | c0.03 | |
| v/c Ratio | | 0.71 | 0.33 | | 0.11 | |
| Uniform Delay, d1 | | 10.3 | 7.0 | | 28.9 | |
| Progression Factor | | 0.20 | 0.70 | | 1.00 | |
| Incremental Delay, d2 | | 0.9 | 0.3 | | 0.5 | |
| Delay (s) | | 2.9 | 5.2 | | 29.4 | |
| Level of Service | | A | A | | C | |
| Approach Delay (s) | | 2.9 | 5.2 | | 29.4 | |
| Approach LOS | | A | A | | C | |

| Intersection Summary | | | |
|-----------------------------------|-------|----------------------|-----|
| HCM Average Control Delay | 4.4 | HCM Level of Service | A |
| HCM Volume to Capacity ratio | 0.54 | | |
| Actuated Cycle Length (s) | 100.0 | Sum of lost time (s) | 8.0 |
| Intersection Capacity Utilization | 59.8% | ICU Level of Service | B |
| Analysis Period (min) | 15 | | |

c Critical Lane Group

HCM Signalized Intersection Capacity Analysis
 3: H STREET & 10th STREET

PM Peak - Total Future_IMP
 7/17/2007



| Movement | EBL | EBT | EBR | WBL | WBT | WBR | NBL | NBT | NBR | SBL | SBT | SBR |
|------------------------|------|-------|------|------|--------|------|------|-------|------|------|------|------|
| Lane Configurations | | ↑↑ | | | ↑↑ | | | ↑ | | | ↑ | |
| Ideal Flow (vphpl) | 1900 | 1900 | 1900 | 1900 | 1900 | 1900 | 1900 | 1900 | 1900 | 1900 | 1900 | 1900 |
| Total Lost time (s) | | 4.0 | | | 4.0 | | | 4.0 | | | 4.0 | |
| Lane Util. Factor | | 0.95 | | | 0.95 | | | 1.00 | | | 1.00 | |
| Frt | | 0.99 | | | 1.00 | | | 0.94 | | | 0.98 | |
| Flt Protected | | 1.00 | | | 0.99 | | | 0.97 | | | 0.99 | |
| Satd. Flow (prot) | | 3516 | | | 3510 | | | 1698 | | | 1798 | |
| Flt Permitted | | 1.00 | | | 0.53 | | | 0.74 | | | 0.90 | |
| Satd. Flow (perm) | | 3516 | | | 1874 | | | 1285 | | | 1632 | |
| Volume (vph) | 0 | 1366 | 53 | 73 | 577 | 0 | 78 | 0 | 55 | 34 | 79 | 19 |
| Peak-hour factor, PHF | 0.25 | 0.96 | 0.83 | 0.59 | 0.92 | 0.25 | 0.82 | 0.25 | 0.63 | 0.77 | 0.78 | 0.66 |
| Adj. Flow (vph) | 0 | 1423 | 64 | 124 | 627 | 0 | 95 | 0 | 87 | 44 | 101 | 29 |
| RTOR Reduction (vph) | 0 | 3 | 0 | 0 | 0 | 0 | 0 | 33 | 0 | 0 | 7 | 0 |
| Lane Group Flow (vph) | 0 | 1484 | 0 | 0 | 751 | 0 | 0 | 149 | 0 | 0 | 167 | 0 |
| Turn Type | | | | Perm | | Perm | | | Perm | | | |
| Protected Phases | | 4 | | | 8 | | | 2 | | | 6 | |
| Permitted Phases | | | | 8 | | | 2 | | | 6 | | |
| Actuated Green, G (s) | | 61.0 | | | 61.0 | | | 28.0 | | | 28.0 | |
| Effective Green, g (s) | | 62.0 | | | 62.0 | | | 30.0 | | | 30.0 | |
| Actuated g/C Ratio | | 0.62 | | | 0.62 | | | 0.30 | | | 0.30 | |
| Clearance Time (s) | | 5.0 | | | 5.0 | | | 6.0 | | | 6.0 | |
| Lane Grp Cap (vph) | | 2180 | | | 1162 | | | 386 | | | 490 | |
| v/s Ratio Prot | | c0.42 | | | | | | | | | | |
| v/s Ratio Perm | | | | | 0.40 | | | c0.12 | | | 0.10 | |
| v/c Ratio | | 0.68 | | | 1.03dl | | | 0.39 | | | 0.34 | |
| Uniform Delay, d1 | | 12.5 | | | 12.0 | | | 27.7 | | | 27.3 | |
| Progression Factor | | 0.08 | | | 1.00 | | | 1.00 | | | 1.00 | |
| Incremental Delay, d2 | | 1.2 | | | 2.8 | | | 2.9 | | | 1.9 | |
| Delay (s) | | 2.2 | | | 14.8 | | | 30.6 | | | 29.2 | |
| Level of Service | | A | | | B | | | C | | | C | |
| Approach Delay (s) | | 2.2 | | | 14.8 | | | 30.6 | | | 29.2 | |
| Approach LOS | | A | | | B | | | C | | | C | |

Intersection Summary

| | | | |
|-----------------------------------|-------|----------------------|-----|
| HCM Average Control Delay | 9.7 | HCM Level of Service | A |
| HCM Volume to Capacity ratio | 0.58 | | |
| Actuated Cycle Length (s) | 100.0 | Sum of lost time (s) | 8.0 |
| Intersection Capacity Utilization | 81.9% | ICU Level of Service | D |
| Analysis Period (min) | 15 | | |

dl Defacto Left Lane. Recode with 1 though lane as a left lane.

c Critical Lane Group

HCM Unsignalized Intersection Capacity Analysis
 4: G STREET & 10th STREET

PM Peak - Total Future_IMP
 7/17/2007

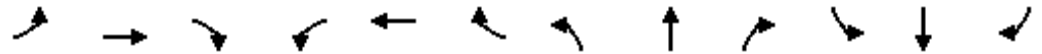

| Movement | EBL | EBT | EBR | WBL | WBT | WBR | NBL | NBT | NBR | SBL | SBT | SBR |
|------------------------|------|------|------|------|------|------|------|------|------|------|------|------|
| Lane Configurations | | | | | ↕ | | | ↕ | | | ↕ | |
| Sign Control | Stop | | | Stop | | | Stop | | | Stop | | |
| Volume (vph) | 0 | 0 | 0 | 6 | 73 | 29 | 17 | 105 | 0 | 0 | 97 | 21 |
| Peak Hour Factor | 0.25 | 0.25 | 0.25 | 0.38 | 0.78 | 0.75 | 0.71 | 0.81 | 0.25 | 0.25 | 0.90 | 0.90 |
| Hourly flow rate (vph) | 0 | 0 | 0 | 16 | 94 | 39 | 24 | 130 | 0 | 0 | 108 | 23 |

| Direction, Lane # | WB 1 | NB 1 | SB 1 |
|-----------------------|-------|------|-------|
| Volume Total (vph) | 148 | 154 | 131 |
| Volume Left (vph) | 16 | 24 | 0 |
| Volume Right (vph) | 39 | 0 | 23 |
| Hadj (s) | -0.10 | 0.07 | -0.07 |
| Departure Headway (s) | 4.4 | 4.5 | 4.4 |
| Degree Utilization, x | 0.18 | 0.19 | 0.16 |
| Capacity (veh/h) | 757 | 773 | 785 |
| Control Delay (s) | 8.4 | 8.5 | 8.2 |
| Approach Delay (s) | 8.4 | 8.5 | 8.2 |
| Approach LOS | A | A | A |

| Intersection Summary | | |
|-----------------------------------|-------|------------------------|
| Delay | | 8.4 |
| HCM Level of Service | | A |
| Intersection Capacity Utilization | 25.7% | ICU Level of Service A |
| Analysis Period (min) | | 15 |

HCM Unsignalized Intersection Capacity Analysis
 5: G STREET & 8th STREET

PM Peak - Total Future_IMP
 7/17/2007

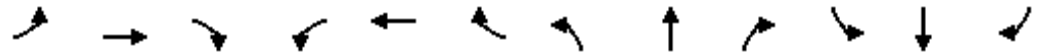

| Movement | EBL | EBT | EBR | WBL | WBT | WBR | NBL | NBT | NBR | SBL | SBT | SBR |
|-----------------------------------|-------------|-------------|-------------|----------------------|------|------|------|------|------|------|------|------|
| Lane Configurations | | | | | ↔ | | | ↔ | | | ↔ | |
| Sign Control | Stop | | | Stop | | | Stop | | | Stop | | |
| Volume (vph) | 0 | 0 | 0 | 7 | 87 | 48 | 27 | 250 | 0 | 0 | 237 | 81 |
| Peak Hour Factor | 0.25 | 0.25 | 0.25 | 0.58 | 0.74 | 0.71 | 0.75 | 0.94 | 0.25 | 0.25 | 0.90 | 0.40 |
| Hourly flow rate (vph) | 0 | 0 | 0 | 12 | 118 | 68 | 36 | 266 | 0 | 0 | 263 | 202 |
| Direction, Lane # | WB 1 | NB 1 | SB 1 | | | | | | | | | |
| Volume Total (vph) | 197 | 302 | 466 | | | | | | | | | |
| Volume Left (vph) | 12 | 36 | 0 | | | | | | | | | |
| Volume Right (vph) | 68 | 0 | 203 | | | | | | | | | |
| Hadj (s) | -0.16 | 0.06 | -0.23 | | | | | | | | | |
| Departure Headway (s) | 5.6 | 5.1 | 4.7 | | | | | | | | | |
| Degree Utilization, x | 0.30 | 0.43 | 0.61 | | | | | | | | | |
| Capacity (veh/h) | 586 | 673 | 746 | | | | | | | | | |
| Control Delay (s) | 11.0 | 12.0 | 14.6 | | | | | | | | | |
| Approach Delay (s) | 11.0 | 12.0 | 14.6 | | | | | | | | | |
| Approach LOS | B | B | B | | | | | | | | | |
| Intersection Summary | | | | | | | | | | | | |
| Delay | | | 13.0 | | | | | | | | | |
| HCM Level of Service | | | B | | | | | | | | | |
| Intersection Capacity Utilization | | | 49.9% | ICU Level of Service | | | | | | | | A |
| Analysis Period (min) | | | 15 | | | | | | | | | |



| Movement | EBL | EBR | NBL | NBT | SBT | SBR |
|-----------------------------------|-------------|-------------|-------------|----------------------|------|------|
| Lane Configurations | | | | | | |
| Sign Control | Stop | | | Free | Free | |
| Grade | 0% | | | 0% | 0% | |
| Volume (veh/h) | 18 | 13 | 39 | 69 | 83 | 85 |
| Peak Hour Factor | 0.92 | 0.92 | 0.92 | 0.92 | 0.92 | 0.92 |
| Hourly flow rate (vph) | 20 | 14 | 42 | 75 | 90 | 92 |
| Pedestrians | | | | | | |
| Lane Width (ft) | | | | | | |
| Walking Speed (ft/s) | | | | | | |
| Percent Blockage | | | | | | |
| Right turn flare (veh) | | | | | | |
| Median type | None | | | | | |
| Median storage (veh) | | | | | | |
| Upstream signal (ft) | | | | | 199 | |
| pX, platoon unblocked | | | | | | |
| vC, conflicting volume | 296 | 136 | 183 | | | |
| vC1, stage 1 conf vol | | | | | | |
| vC2, stage 2 conf vol | | | | | | |
| vCu, unblocked vol | 296 | 136 | 183 | | | |
| tC, single (s) | 6.4 | 6.2 | 4.1 | | | |
| tC, 2 stage (s) | | | | | | |
| tF (s) | 3.5 | 3.3 | 2.2 | | | |
| p0 queue free % | 97 | 98 | 97 | | | |
| cM capacity (veh/h) | 674 | 912 | 1392 | | | |
| Direction, Lane # | EB 1 | NB 1 | SB 1 | | | |
| Volume Total | 34 | 117 | 183 | | | |
| Volume Left | 20 | 42 | 0 | | | |
| Volume Right | 14 | 0 | 92 | | | |
| cSH | 757 | 1392 | 1700 | | | |
| Volume to Capacity | 0.04 | 0.03 | 0.11 | | | |
| Queue Length 95th (ft) | 3 | 2 | 0 | | | |
| Control Delay (s) | 10.0 | 2.9 | 0.0 | | | |
| Lane LOS | A | A | | | | |
| Approach Delay (s) | 10.0 | 2.9 | 0.0 | | | |
| Approach LOS | A | | | | | |
| Intersection Summary | | | | | | |
| Average Delay | | | 2.0 | | | |
| Intersection Capacity Utilization | | 28.7% | | ICU Level of Service | | A |
| Analysis Period (min) | | | 15 | | | |

HCM Unsignalized Intersection Capacity Analysis
7: Alley Access West & 8th STREET

PM Peak - Total Future_IMP
7/17/2007



| Movement | WBL | WBR | NBT | NBR | SBL | SBT |
|------------------------|------|------|------|------|------|------|
| Lane Configurations | ↔ | | ↔ | | ↔ | |
| Sign Control | Stop | | Free | | Free | |
| Grade | 0% | | 0% | | 0% | |
| Volume (veh/h) | 105 | 126 | 271 | 28 | 109 | 212 |
| Peak Hour Factor | 0.92 | 0.92 | 0.92 | 0.92 | 0.92 | 0.92 |
| Hourly flow rate (vph) | 114 | 137 | 295 | 30 | 118 | 230 |
| Pedestrians | | | | | | |
| Lane Width (ft) | | | | | | |
| Walking Speed (ft/s) | | | | | | |
| Percent Blockage | | | | | | |
| Right turn flare (veh) | | | | | | |
| Median type | None | | | | | |
| Median storage (veh) | | | | | | |
| Upstream signal (ft) | 221 | | | | | |
| pX, platoon unblocked | | | | | | |
| vC, conflicting volume | 777 | 310 | | | 325 | |
| vC1, stage 1 conf vol | | | | | | |
| vC2, stage 2 conf vol | | | | | | |
| vCu, unblocked vol | 777 | 310 | | | 325 | |
| tC, single (s) | 6.4 | 6.2 | | | 4.1 | |
| tC, 2 stage (s) | | | | | | |
| tF (s) | 3.5 | 3.3 | | | 2.2 | |
| p0 queue free % | 65 | 81 | | | 90 | |
| cM capacity (veh/h) | 330 | 730 | | | 1235 | |

| Direction, Lane # | WB 1 | NB 1 | SB 1 |
|------------------------|------|------|------|
| Volume Total | 251 | 325 | 349 |
| Volume Left | 114 | 0 | 118 |
| Volume Right | 137 | 30 | 0 |
| cSH | 471 | 1700 | 1235 |
| Volume to Capacity | 0.53 | 0.19 | 0.10 |
| Queue Length 95th (ft) | 77 | 0 | 8 |
| Control Delay (s) | 21.0 | 0.0 | 3.4 |
| Lane LOS | C | | A |
| Approach Delay (s) | 21.0 | 0.0 | 3.4 |
| Approach LOS | C | | |

| Intersection Summary | | | |
|-----------------------------------|-------|----------------------|-----|
| Average Delay | | | 7.0 |
| Intersection Capacity Utilization | 56.7% | ICU Level of Service | B |
| Analysis Period (min) | | | 15 |

APPENDIX E
Transportation Management Plan

Transportation Management Plan for 8th and H Street Planned Unit Development

INTRODUCTION

This document presents a proposed Transportation Management Plan (TMP) for the 8th and H Street Planned Unit Development. The development site is situated south of H Street between 8th and 10th Streets in Northeast Washington, D.C. The site is occupied by a shopping center, and would be redeveloped with mixed residential and retail uses supported by underground parking.

The primary goal of this TMP is to reduce traffic congestion and related pollution problems in the local and regional areas of the site by influencing traveling choices and patterns towards the use of transportation modes other than single-occupant motor vehicles. The primary objective is to minimize the potential traffic and parking impacts of the proposed development on internal and external roadways, and within the adjacent residential communities. The TMP therefore applies to the peak hour and daily trips that would be generated by all users of the development, including employees, residents, visitors and retail patrons.

This TMP document is in keeping with the requirements of the District Department of Transportation (DDOT), and the City's transit oriented development policies and strategies described in "*Trans-Formation: Recreating Transit-Oriented Neighborhood Centers in Washington, DC*" September 2002. The TMP also follows the guidelines presented in the GSA/MWCOG/NCPC Transportation Management Program Handbook¹. The key components of the TMP are presented below.

POTENTIAL TMP MEASURES

As indicated above, the primary objective of the TMP would be to reduce the potential impacts of the proposed development by managing traffic and parking demand. Towards this end, the following potential measures have been identified for consideration by the Development Team, DDOT and WMATA.

- **Transportation Services Coordinator**. This task will be the responsibility of the property management group. Responsibilities will include administering the TMP strategies, including the development and distribution of informational and promotional brochures regarding ridesharing and various transit services, and the administration of a ridesharing database and information matching system.

¹ "*Implementing a Successful Transportation Management Program, 2008*", General Services Administration (GSA), Metropolitan Washington Council of Governments (MWCOG), National Capital Planning Commission (NCPC).

- **Transit Services.**
 - **Continuation/Enhancement of Metrobus Services.** The Developer will work with DDOT and WMATA to enhance transit accessibility and ridership amenities (including improved bus shelters) along H and 8th Streets. These streets are used by several Metrobus routes which provide connections to several Metro stations and other areas of the District and adjacent jurisdictions. The District also plans to provide streetcar services along the site on both H and 8th Streets. The H Street Streetcar line would run between Union Station and the Benning Road Metro Station. The 8th Street streetcar line would run from H Street NE to M Street SE, with connections to additional streetcar lines serving the Anacostia waterfront and corridors east of the Anacostia River.
 - **Transit Subsidy.** At the commencement of the employment of a new employee, the property management group will request that retailers provide that employee with a SmarTrip Card with the value of \$20.00 to encourage the use of transit.
- **Shared Vehicles.** The Developer will reserve two (2) parking spaces within the proposed garages, for use by shared vehicles (such as Zipcars).
- **Pedestrian and Bicycle Linkages.** The developer will encourage all alternative transportation modes including walking and bicycling to reduce the roadway traffic congestion and related environmental impacts. Wide sidewalks with good pedestrian lighting and tree shade will be provided along the site frontage. These improvements would create a pleasant walking and bicycling experience along the site and enhance access to and use of existing and future transit facilities and services. The proposed development will include an appropriate number of bicycle parking spaces in the garages, in keeping with the DDOT requirement (i.e., five percent of the required off-street automobile parking spaces). All bicycle parking spaces will comply with the Zoning Regulations.
- **Ride-matching/Ridesharing Program.** Employees and residents who wish to carpool would be provided a list of like-minded persons, and will also be referred to other carpool matching services sponsored by the Metropolitan Washington Council of Governments. Three (3) carpool parking spaces will be provided within the parking garage.
- **Guaranteed Ride Home Program.** Sponsored by the Metropolitan Washington Council of Governments and coordinated by the on-site Transportation Services Coordinator, this program ensures employee commuters who regularly carpool, vanpool, bike, walk or take transit to work with a reliable ride home when they need to work overtime, or another unexpected reason to leave arises. The ride, using a taxi or other transit, is free to the user.